



HOTSTART.



Product Catalog

Engine Heaters

Oil Heaters

Controls

Accessories

HOTSTART... YOUR ENGINE HEATING EXPERTS!

HOTSTART was established in 1942 with the original patent for engine coolant heating. We design and manufacture engine heating equipment and accessories that provide easy starts, reduced fuel consumption, reduced wear, and reduced emissions. As a world wide distributor of electric heating equipment for gasoline and diesel engines, HOTSTART has the experience and expertise to solve your engine heating problems.

Contact us today.



HOTSTART Engine Heaters

Easy Starts...

- Saves warm-up time
- Saves fuel
- Prolongs battery life
- Provides immediate defrosting

Reduces Engine Wear...

- 90% of engine wear is due to low water jacket temperature
- Stops destructive condensation
- Extends time between overhauls

Protects the Environment...

- Eliminates "White Smoke" upon start-up
- Reduces idle time
- Engine is ready for clean full power operation
- Reduces noise pollution
- No high speed idle

Tank Style Coolant Heaters That Meet Heating Requirements For a Wide Range of Engine Sizes and Applications.

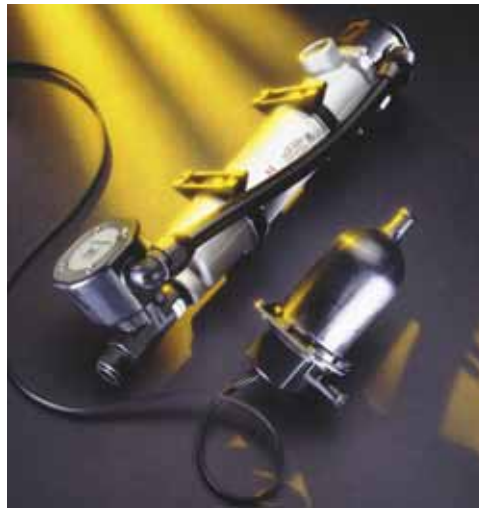

- Constant circulation of coolant through the engine achieves even heat distribution.
- One-piece, heavy-duty, pressure die-cast aluminum tank with a bolt-on flange element assembly.
- All parts replaceable — easy to service.
- Most models classified weathertight.
- Many models available for Class I, Group D (Hazardous Locations) applications.
- Various voltages and phases available.
- CSA C/US and UL C/US approved.

Industrial Lube Oil Heaters and Process Oil Heaters. Multiple Sizes Available for Every Oil Heating Need.

- Reduces engine wear.
- Immediate flow of warm oil to critical engine parts.
- Stops destructive condensation and the forming of sludge in oil.
- Warm oil allows easier starts and prolongs battery life.
- Models designed for heating transmission fluid, hydraulic oil and diesel fuel.
- Low watt density elements assure safe heating of oils and will not char or coke.
- Thermostat control available and recommended for all models.
- Innovative threadless design V-clamp style mounting adapter available.



Battery Warming Pads and Thermal Wraps Improve Cranking Power in the Coldest Conditions.



- Flexible SBR rubber pads are designed for installation under the battery to heat from the bottom up.
- Blanket-style heaters and pad heaters are impervious to battery acid and oil.
- Pad models for multiple battery applications available with accessory cords and thermostat assembly.
- Blanket-style warmers provide greater heat rise than plates or pads.
- Engineered to maintain batteries at 80°F/27°C to ensure full cranking power.

Silicone Hot Pads are Flexible and Easy to Install.

- Ideal for oil pans, hydraulic reservoirs, engine blocks and hydraulic cylinders.
- Durable silicone/fiberglass cover resists abrasion.

Thermostat Controls, Complete Control Systems and Other Accessories Ensure Proper and Efficient Performance of Kim Hotstart Heaters.

- General purpose, weathertight and explosion proof thermostats available for all engine heating, oil heating and battery heating applications.
- Fixed temperature and adjustable.
- Oil pressure switches for automatic cut-off of heaters on engine start-up.
- Complete control systems for 3 phase and high voltage engine preheaters factory assembled in electrical boxes for ease of installation.

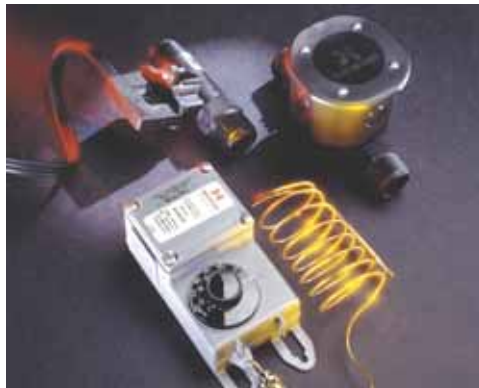

All Direct Immersion Block Heaters Carry CSA C/US approval and are CE compliant.



- Long life Incoloy elements withstand higher temperatures to reduce element failure.
- Reduced heat in terminal connection area.
- Resists scale build-up on element surface.
- Tensile strength of Incoloy is three times that of copper, making it much less susceptible to engine and road vibration.
- Available in 120 volt and 240 volt.
- The 6ft. power cord and plug carries a lifetime warranty; standard equipment on all in-block heaters.
- Optional thermostat control and "Y" harness available for all Kim-Glo heaters.



HOTSTART[®]

TABLE OF CONTENTS

Heater Installation Guides:
Tank-style – Page 40
In-block – Page 56
How to Specify an Engine Heater and Conversion Charts – Page 58
Industrial Circulating Systems – Page 16, 17, 59

Custom Products

Call for information on:
Battery Chargers
Wiring Harnesses
Air Intake Heaters
Diesel Driven Heating Systems
Other Specialty Products

Pages 6 -18



Section 1

Tank Style Coolant Heaters
Weathertight Design
Original Equip. Replacement Heaters
Circulating System with Pump

Pages 20 - 24



Section 2

Tank Style Coolant Heaters
Class 1, Group D for Hazardous Locations

Pages 26 - 32



Section 3

Industrial Lube Oil Heaters
Lube Oil Heaters with Thermostat
Process Immersion Heaters with Fixed or Adjustable Thermostat

Pages 34 - 39



Section 4

Temperature Controls
Pressure Switch
Magnetic Contactors
Junction Boxes
Complete Control Systems

Pages 42 - 44



Section 5

Battery Warming Pads and Accessories
Blanket Style Battery Warmers
Silicone Hot Pads

Pages 46 - 57



Section 6

In-block Direct Immersion Heaters
In-line Coolant Heater
Electrical Cords for In-block Heaters
Thermocords
Flush Mount Kits and Accessories

Section 1

Industrial Tank Style Coolant Heaters



Small Tank Heaters

*TPS Model
Single Phase
500-2000 Watts
120V & 240V*



Ambient Above -20° F	Ambient Below -20° F	Model Number	Volts	Watts	Phase	Amps	Thermostat Range	
							On	Off
150 Cubic Inch or Less	150 Cubic Inch or Less	TPS051GT8-000	120	500	1	4.2	80°F	100°F
		TPS051GT10-000	120	500	1	4.2	100°F	120°F
		TPS051GT12-000	120	500	1	4.2	120°F	140°F
		TPS052GT8-000	240	500	1	2.1	80°F	100°F
		TPS052GT10-000	240	500	1	2.1	100°F	120°F
		TPS052GT12-000	240	500	1	2.1	120°F	140°F
350 Cubic Inch or Less	200 Cubic Inch or Less	TPS101GT8-000	120	1000	1	8.4	80°F	100°F
		TPS101GT10-000	120	1000	1	8.4	100°F	120°F
		TPS101GT12-000	120	1000	1	8.4	120°F	140°F
		TPS102GT8-000	240	1000	1	4.2	80°F	100°F
		TPS102GT10-000	240	1000	1	4.2	100°F	120°F
		TPS102GT12-000	240	1000	1	4.2	120°F	140°F
350 — 500 Cubic Inch or Less	200 — 300 Cubic Inch or Less	TPS151GT8-000	120	1500	1	12.5	80°F	100°F
		TPS151GT10-000	120	1500	1	12.5	100°F	120°F
		TPS151GT12-000	120	1500	1	12.5	120°F	140°F
		TPS152GT8-000	240	1500	1	6.3	80°F	100°F
		TPS152GT10-000	240	1500	1	6.3	100°F	120°F
		TPS152GT12-000	240	1500	1	6.3	120°F	140°F
500 — 700 Cubic Inch or Less	300 — 400 Cubic Inch or Less	TPS181GT8-000	120	1800	1	15	80°F	100°F
		TPS181GT10-000	120	1800	1	15	100°F	120°F
		TPS181GT12-000	120	1800	1	15	120°F	140°F
		TPS202GT8-000	240	2000	1	8.3	80°F	100°F
		TPS202GT10-000	240	2000	1	8.3	100°F	120°F
		TPS202GT12-000	240	2000	1	8.3	120°F	140°F

HOTSTART TPS tank heaters are constructed from a durable, high-impact plastic. Every heater is assembled with a built-in thermostat and 4-foot power cord.

Replacement Parts

For TPS Model heaters

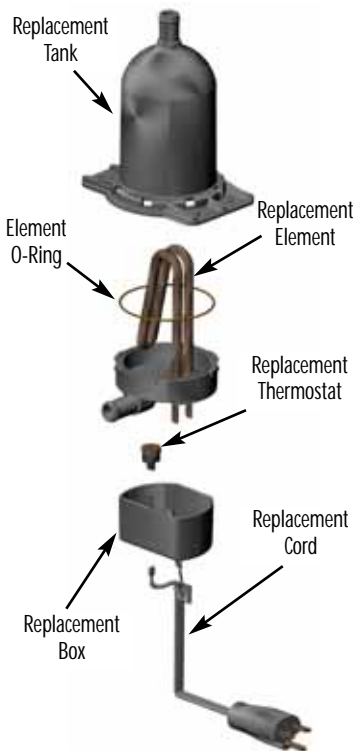

Model Number	Volts	Watts	Thermostat Range		Replaceable Parts					
			On	Off	T-Stat	Element	Tank	Box	Power Cord	Element O-ring
TPS051GT8-000	120	500	80°F	100°F	LSU-8	REPS051T8	TPS-T	CPS-1	11P48UU	TPS-BOR
TPS051GT10-000	120	500	100°F	120°F	LSU-10	REPS051T10	TPS-T	CPS-1	11P48UU	TPS-BOR
TPS051GT12-000	120	500	120°F	140°F	LSU-12	REPS051T12	TPS-T	CPS-1	11P48UU	TPS-BOR
TPS052GT8-000	240	500	80°F	100°F	LSU-8	REPS052T8	TPS-T	CPS-1	21P48UU	TPS-BOR
TPS052GT10-000	240	500	100°F	120°F	LSU-10	REPS052T10	TPS-T	CPS-1	21P48UU	TPS-BOR
TPS052GT12-000	240	500	120°F	140°F	LSU-12	REPS052T12	TPS-T	CPS-1	21P48UU	TPS-BOR
TPS101GT8-000	120	1000	80°F	100°F	LSU-8	REPS101T8	TPS-T	CPS-1	11P48UU	TPS-BOR
TPS101GT10-000	120	1000	100°F	120°F	LSU-10	REPS101T10	TPS-T	CPS-1	11P48UU	TPS-BOR
TPS101GT12-000	120	1000	120°F	140°F	LSU-12	REPS101T12	TPS-T	CPS-1	11P48UU	TPS-BOR
TPS102GT8-000	240	1000	80°F	100°F	LSU-8	REPS102T8	TPS-T	CPS-1	21P48UU	TPS-BOR
TPS102GT10-000	240	1000	100°F	120°F	LSU-10	REPS102T10	TPS-T	CPS-1	21P48UU	TPS-BOR
TPS102GT12-000	240	1000	120°F	140°F	LSU-12	REPS102T12	TPS-T	CPS-1	21P48UU	TPS-BOR
TPS151GT8-000	120	1500	80°F	100°F	LSU-8	REPS151T8	TPS-T	CPS-1	11P48UU	TPS-BOR
TPS151GT10-000	120	1500	100°F	120°F	LSU-10	REPS151T10	TPS-T	CPS-1	11P48UU	TPS-BOR
TPS151GT12-000	120	1500	120°F	140°F	LSU-12	REPS151T12	TPS-T	CPS-1	11P48UU	TPS-BOR
TPS152GT8-000	240	1500	80°F	100°F	LSU-8	REPS152T8	TPS-T	CPS-1	21P48UU	TPS-BOR
TPS152GT10-000	240	1500	100°F	120°F	LSU-10	REPS152T10	TPS-T	CPS-1	21P48UU	TPS-BOR
TPS152GT12-000	240	1500	120°F	140°F	LSU-12	REPS152T12	TPS-T	CPS-1	21P48UU	TPS-BOR
TPS181GT8-000	120	1800	80°F	100°F	LSU-8	REPS181T8	TPS-T	CPS-1	12P48UU	TPS-BOR
TPS181GT10-000	120	1800	100°F	120°F	LSU-10	REPS181T10	TPS-T	CPS-1	12P48UU	TPS-BOR
TPS181GT12-000	120	1800	120°F	140°F	LSU-12	REPS181T12	TPS-T	CPS-1	12P48UU	TPS-BOR
TPS202GT8-000	240	2000	80°F	100°F	LSU-8	REPS202T8	TPS-T	CPS-1	21P48UU	TPS-BOR
TPS202GT10-000	240	2000	100°F	120°F	LSU-10	REPS202T10	TPS-T	CPS-1	21P48UU	TPS-BOR
TPS202GT12-000	240	2000	120°F	140°F	LSU-12	REPS202T12	TPS-T	CPS-1	21P48UU	TPS-BOR

Small Tank Heaters

TPS Model w/in-line adjustable and remote thread-in fixed thermostat
Single Phase
500-2000 Watts
120V & 240V



Ambient Above -20° F	Ambient Below -20° F	Model Number	Volts	Watts	Phase	Amps	Thermostat Range	
							On	Off
150 Cubic Inch or Less	150 Cubic Inch or Less	TPS051GT12-001*	120	500	1	4.2	100°F	120°F
		TPS051GT12-A00	120	500	1	4.2	ADJUSTABLE	
		TPS052GT12-001*	240	500	1	2.1	100°F	120°F
		TPS052GT12-A00	240	500	1	2.1	ADJUSTABLE	
350 Cubic Inch or Less	200 Cubic Inch or Less	TPS101GT12-001*	120	1000	1	8.4	100°F	120°F
		TPS101GT12-A00	120	1000	1	8.4	ADJUSTABLE	
		TPS102GT12-001*	240	1000	1	4.2	100°F	120°F
		TPS102GT12-A00	240	1000	1	4.2	ADJUSTABLE	
350 — 500 Cubic Inch or Less	200 — 300 Cubic Inch or Less	TPS151GT12-001*	120	1500	1	12.5	100°F	120°F
		TPS151GT12-A00	120	1500	1	12.5	ADJUSTABLE	
		TPS152GT12-001*	240	1500	1	6.3	100°F	120°F
		TPS152GT12-A00	240	1500	1	6.3	ADJUSTABLE	
500 — 700 Cubic Inch or Less	300 — 400 Cubic Inch or Less	TPS181GT12-001*	120	1800	1	15	100°F	120°F
		TPS181GT12-A00	120	1800	1	15	ADJUSTABLE	
		TPS202GT12-001*	240	2000	1	8.3	100°F	120°F
		TPS202GT12-A00	240	2000	1	8.3	ADJUSTABLE	

* Remote thread-in fixed temperature thermostat

ADJUSTABLE 90-130°F
(On differential - 20° F)

In-line thermostat options:

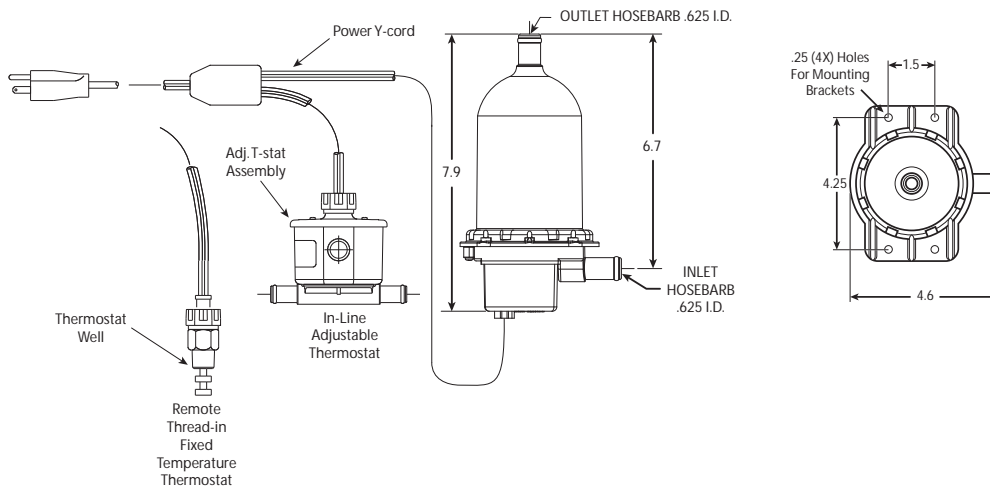

Model Number	Volts	Watts	Thermostat Range On Off	Replaceable Parts			
				Sensing Unit	Element	Power Y-cord	Thermostat Well
TPS051GT12-001*	120	500	100°F 120°F	LSU-10	REPS051T12	TPS-YC1	TW2374-1
TPS051GT12-A00	120	500	ADJUSTABLE	RSU90-130	REPS051T12	#	#
TPS052GT12-001*	240	500	100°F 120°F	LSU-10	REPS052T12	TPS-YC2	TW2374-1
TPS052GT12-A00	240	500	ADJUSTABLE	RSU90-130	REPS052T12	#	#
TPS101GT12-001*	120	1000	100°F 120°F	LSU-10	REPS101T12	TPS-YC1	TW2374-1
TPS101GT12-A00	120	1000	ADJUSTABLE	RSU90-130	REPS101T12	#	#
TPS102GT12-001*	240	1000	100°F 120°F	LSU-10	REPS102T12	TPS-YC2	TW2374-1
TPS102GT12-A00	240	1000	ADJUSTABLE	RSU90-130	REPS102T12	#	#
TPS151GT12-001*	120	1500	100°F 120°F	LSU-10	REPS151T12	TPS-YC1	TW2374-1
TPS151GT12-A00	120	1500	ADJUSTABLE	RSU90-130	REPS151T12	#	#
TPS152GT12-001*	240	1500	100°F 120°F	LSU-10	REPS152T12	TPS-YC2	TW2374-1
TPS152GT12-A00	240	1500	ADJUSTABLE	RSU90-130	REPS152T12	#	#
TPS181GT12-001*	120	1800	100°F 120°F	LSU-10	REPS181T12	12P16H54S54X10UU	TW2374-1
TPS181GT12-A00	120	1800	ADJUSTABLE	RSU90-130	REPS181T12	#	#
TPS202GT12-001*	240	2000	100°F 120°F	LSU-10	REPS202T12	TPS-YC2	TW2374-1
TPS202GT12-A00	240	2000	ADJUSTABLE	RSU90-130	REPS202T12	#	#

* Remote thread-in fixed temperature thermostat

Call Factory

Replacement Parts

For TPS Model heaters w/in-line adjustable and remote thread-in fixed thermostat

Common Replacement Parts For ALL TPS Model Heaters:

- Tank
- Box
- Element O-ring

See table on p. 6

Industrial Tank Heaters

(Conduit Connection)

1500 - 5000 watt
Weathertight
Single Phase



CB Model without thermostat.



CB Model assembled with thermostat.



CL Model without thermostat.



CL Model assembled with thermostat.



Ambient Above -20° F	Ambient Below -20° F	Model Number without Thermostat	Model Number with Thermostat (see chart 1)	Volts	Watts	Phase	Amps	Fig.* No.
350 — 500 Cubic Inch or Less	200 — 300 Cubic Inch or Less	CB115100-000	CB1151XX-000	120	1500	1	12.5	1
		CB115800-000	CB1158XX-000	208	1500	1	7.2	1
		CB115200-000	CB1152XX-000	240	1500	1	6.3	1
		CB115700-000	CB1157XX-000	277	1500	1	5.4	1
		CB115300-000	CB1153XX-000	380	1500	1	3.9	1
		CB115400-000	CB1154XX-000	480	1500	1	3.1	1
500 — 600 Cubic Inch or Less	300 — 400 Cubic Inch or Less	CB120100-000	CB1201XX-000	120	2000	1	16.7	1
		CB120800-000	CB1208XX-000	208	2000	1	9.6	1
		CB120200-000	CB1202XX-000	240	2000	1	8.3	1
		CB120300-000	CB1203XX-000	380	2000	1	5.3	1
		CB120400-000	CB1204XX-000	480	2000	1	4.2	1
600 — 800 Cubic Inch or Less	400 — 500 Cubic Inch or Less	CB125100-000	CB1251XX-000	120	2500	1	20.8	1
		CB125800-000	CB1258XX-000	208	2500	1	12.0	1
		CB125200-000	CB1252XX-000	240	2500	1	10.4	1
		CB125700-000	CB1257XX-000	277	2500	1	9.0	1
		CB125300-000	CB1253XX-000	380	2500	1	6.6	1
		CB125400-000	CB1254XX-000	480	2500	1	5.2	1
800 — 1000 Cubic Inch or Less	500 — 600 Cubic Inch or Less	CL130100-100	CL1301XX-100	120	3000	1	25.0	3
		CL130800-100	CL1308XX-100	208	3000	1	14.4	3
		CL130200-100	CL1302XX-100	240	3000	1	12.5	3
		CL130700-100	CL1307XX-100	277	3000	1	10.8	3
		CL130300-100	CL1303XX-100	380	3000	1	7.9	3
		CL130400-100	CL1304XX-100	480	3000	1	6.3	3
1000 — 1350 Cubic Inch or Less	600 — 800 Cubic Inch or Less	CL140800-100	CL1408XX-100	208	4000	1	19.2	3
		CL140200-100	CL1402XX-100	240	4000	1	16.7	3
		CL140700-100	CL1407XX-100	277	4000	1	14.4	3
		CL140300-100	CL1403XX-100	380	4000	1	10.5	3
		CL140400-100	CL1404XX-100	480	4000	1	8.3	3
1350 — 1650 Cubic Inch or Less	800 — 1000 Cubic Inch or Less	CL150800-100	CL1508XX-100	208	5000	1	24.0	3
		CL150200-100	CL1502XX-100	240	5000	1	20.8	3
		CL150700-100	CL1507XX-100	277	5000	1	18.1	3
		CL150300-100	CL1503XX-100	380	5000	1	13.2	3
		CL150400-100	CL1504XX-100	480	5000	1	10.4	3

*Figure Number refers to technical drawings of heaters located on page 14.

INSTALLATION TIPS	
If you require a 1" NPT female thread on the thermostat intake, a coupler is available. Also, for the use of 3/4" or 1" ID heater hose, hose barb adapters are available. See below.	
Part Number	Description
HB-1	1" NPT to 1" hose barb adapter. Installs in 1" NPT female inlet or outlet of the heater.
HB-3/4	1" NPT to 3/4" hose barb adapter. Installs in 1" NPT female inlet or outlet of the heater.
HB-C	1" NPT x 1" NPT aluminum coupler. Installs on 1" NPT inlet to T-Stat and allows the addition of HB-1 or HB-3/4.
HB-K3/4	Kit contains (2) HB-3/4 and (1) HB-C
HB-K1	Kit contains (2) HB-1 and (1) HB-C

CHART 1			
HEATERS WITH THERMOSTATS			
To specify temperature range of thermostat, insert numerical code from chart in place of the XX in model number.			
Example:			
Desired Temperature Range 100° - 120°F			
Catalog Number: Model CB1151XX-000			
Order as: Model CB115110-000			
All heaters over 277v and all 3Ø units must use a control box See Control Systems page 38	TEMPERATURE RANGE		NUMERICAL CODE
	ON	OFF	
	60°F	80°F	06
	80°F	100°F	08
	100°F	120°F	10
120°F	140°F	12	
140°F	160°F	14	
Adjustable 90° - 130°F		A3	

Replacement Parts

For tank-style heaters shown on page 8

Model Number	Volts	Watts	Replaceable Parts					
			Element	Tank	Box	Element O-ring	Mounting Kit	Check Valve
CB115100-000	120	1500	RECB1151	RTB	RTBCB	TMM-OR	FK2	RV-M
CB115800-000	208	1500	RECB1158	RTB	RTBCB	TMM-OR	FK2	RV-M
CB115200-000	240	1500	RECB1152	RTB	RTBCB	TMM-OR	FK2	RV-M
CB115700-000	277	1500	RECB1157	RTB	RTBCB	TMM-OR	FK2	RV-M
CB115300-000	380	1500	RECB1153	RTB	RTBCB	TMM-OR	FK2	RV-M
CB115400-000	480	1500	RECB1154	RTB	RTBCB	TMM-OR	FK2	RV-M
CB120100-000	120	2000	RECB1201	RTB	RTBCB	TMM-OR	FK2	RV-M
CB120800-000	208	2000	RECB1208	RTB	RTBCB	TMM-OR	FK2	RV-M
CB120200-000	240	2000	RECB1202	RTB	RTBCB	TMM-OR	FK2	RV-M
CB120300-000	380	2000	RECB1203	RTB	RTBCB	TMM-OR	FK2	RV-M
CB120400-000	480	2000	RECB1204	RTB	RTBCB	TMM-OR	FK2	RV-M
CB125100-000	120	2500	RECB1251	RTB	RTBCB	TMM-OR	FK2	RV-M
CB125800-000	208	2500	RECB1258	RTB	RTBCB	TMM-OR	FK2	RV-M
CB125200-000	240	2500	RECB1252	RTB	RTBCB	TMM-OR	FK2	RV-M
CB125700-000	277	2500	RECB1257	RTB	RTBCB	TMM-OR	FK2	RV-M
CB125300-000	380	2500	RECB1253	RTB	RTBCB	TMM-OR	FK2	RV-M
CB125400-000	480	2500	RECB1254	RTB	RTBCB	TMM-OR	FK2	RV-M
CL130100-100	120	3000	RECL1301-100	RTL	RTBCL-100	TML-OR	FK6	RV-M
CL130800-100	208	3000	RECL1308-100	RTL	RTBCL-100	TML-OR	FK6	RV-M
CL130200-100	240	3000	RECL1302-100	RTL	RTBCL-100	TML-OR	FK6	RV-M
CL130700-100	277	3000	RECL1307-100	RTL	RTBCL-100	TML-OR	FK6	RV-M
CL130300-100	380	3000	RECL1303-100	RTL	RTBCL-100	TML-OR	FK6	RV-M
CL130400-100	480	3000	RECL1304-100	RTL	RTBCL-100	TML-OR	FK6	RV-M
CL140800-100	208	4000	RECL1408-100	RTL	RTBCL-100	TML-OR	FK6	RV-M
CL140200-100	240	4000	RECL1402-100	RTL	RTBCL-100	TML-OR	FK6	RV-M
CL140700-100	277	4000	RECL1407-100	RTL	RTBCL-100	TML-OR	FK6	RV-M
CL140300-100	380	4000	RECL1403-100	RTL	RTBCL-100	TML-OR	FK6	RV-M
CL140400-100	480	4000	RECL1404-100	RTL	RTBCL-100	TML-OR	FK6	RV-M
CL150800-100	208	5000	RECL1508-100	RTL	RTBCL-100	TML-OR	FK6	RV-M
CL150200-100	240	5000	RECL1502-100	RTL	RTBCL-100	TML-OR	FK6	RV-M
CL150700-100	277	5000	RECL1507-100	RTL	RTBCL-100	TML-OR	FK6	RV-M
CL150300-100	380	5000	RECL1503-100	RTL	RTBCL-100	TML-OR	FK6	RV-M
CL150400-100	480	5000	RECL1504-100	RTL	RTBCL-100	TML-OR	FK6	RV-M

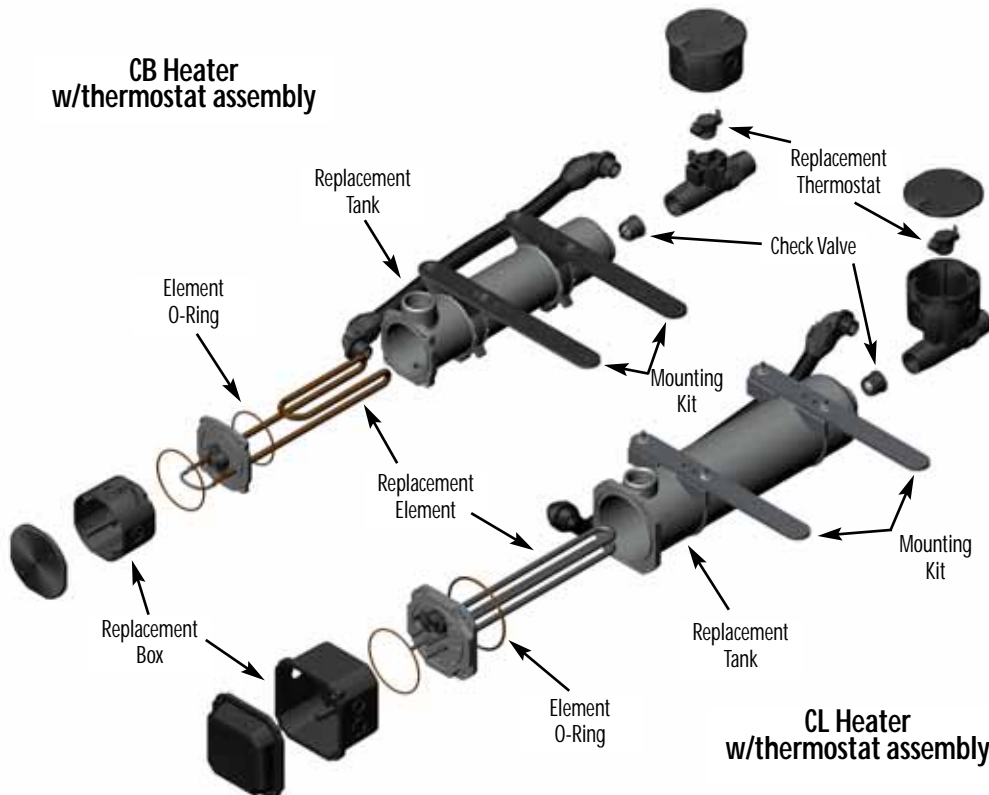

Heaters with Thermostats		
Temperature Range		Thermostat Replacement
ON	OFF	
60°F	80°F	RSU6
80°F	100°F	RSU8
100°F	120°F	RSU10
120°F	140°F	RSU12
140°F	160°F	RSU14
Adjustable 90° - 130°F		RSU90-130

Industrial Tank Heaters

(With Power Cord)

1500 - 4000 watt
Weathertight
Single Phase

SB Models include hi-limit thermostats and carry CSA-C/US approval.



SB Model with power cord; no thermostat



SB Model with thermostat and power cord



SL Model with power cord; no thermostat.



SL Model with thermostat and power cord.

Ambient Above -20° F	Ambient Below -20° F	Model Number without Thermostat	Model Number with Thermostat (see chart 1)	Volts	Watts	Phase	Amps	Fig.* No.
350 — 500 Cubic Inch or Less	200 — 300 Cubic Inch or Less	SB115100-000	SB1151XX-000	120	1500	1	12.5	2
		SB115800-000	SB1158XX-000	208	1500	1	7.2	2
		SB115200-000	SB1152XX-000	240	1500	1	6.3	2
		SB115700-000	SB1157XX-000	277	1500	1	5.4	2
500 — 600 Cubic Inch or Less	300 — 400 Cubic Inch or Less	SB120100-000	SB1201XX-000	120	2000	1	16.7	2
		SB120800-000	SB1208XX-000	208	2000	1	9.6	2
		SB120200-000	SB1202XX-000	240	2000	1	8.3	2
600 — 800 Cubic Inch or Less	400 — 500 Cubic Inch or Less	SB122100-000	SB1221XX-000	120	2250	1	18.8	2
		SB125800-000	SB1258XX-000	208	2500	1	12.0	2
		SB125200-000	SB1252XX-000	240	2500	1	10.4	2
		SB125700-000	SB1257XX-000	277	2500	1	9.0	2
800 — 1000 Cubic Inch or Less	500 — 600 Cubic Inch or Less	SL130100-000	—	120	3000	1	25.0	4
		SL130800-000	SL1308XX-000	208	3000	1	14.4	4
		SL130200-000	SL1302XX-000	240	3000	1	12.5	4
		SL130700-000	SL1307XX-000	277	3000	1	10.8	4
1000 — 1350 Cubic Inch or Less	600 — 800 Cubic Inch or Less	SL140800-000	SL1408XX-000	208	4000	1	19.2	4
		SL140200-000	SL1402XX-000	240	4000	1	16.7	4
		SL140700-000	SL1407XX-000	277	4000	1	14.4	4

*Figure Number refers to technical drawings of heaters located on page 14.

All 208v, 277v and 3000w/120v models come with cord only - no plug.

INSTALLATION TIPS

If you require a 1" NPT female thread on the thermostat intake, a coupler is available. Also, for the use of 3/4" or 1" ID heater hose, hose barb adapters are available. See below.

Part Number	Description
HB-1	1" NPT to 1" hose barb adapter. Installs in 1" NPT female inlet or outlet of the heater.
HB-3/4	1" NPT to 3/4" hose barb adapter. Installs in 1" NPT female inlet or outlet of the heater.
HB-C	1" NPT x 1" NPT aluminum coupler. Installs on 1" NPT inlet to T-Stat and allows the addition of HB-1 or HB-3/4.
HB-K3/4	Kit contains (2) HB-3/4 and (1) HB-C
HB-K1	Kit contains (2) HB-1 and (1) HB-C

CHART 1

HEATERS WITH THERMOSTATS

To specify temperature range of thermostat, insert numerical code from chart in place of the XX in model number.

Example:

Desired Temperature Range 100° - 120°F
Catalog Number: Model SB1151XX-000
Order as: Model SB115110-000

	TEMPERATURE RANGE		NUMERICAL CODE
	ON	OFF	
	60°F	80°F	06
80°F	100°F	08	
100°F	120°F	10	
120°F	140°F	12	
140°F	160°F	14	

Replacement Parts

For tank-style heaters shown on page 10

Model Number	Volts	Watts	Replaceable Parts							
			Element	Tank	Box	Power Cord	Power Cord w/T-stat plug*	Element O-ring	Mount Kit	Check Valve
SB115100-000	120	1500	RESB1151	RTB	RTBSB	RTHC1-16	RHS1-16	TMM-OR	FK2	RV-M
SB115800-000	208	1500	RESB1158	RTB	RTBSB	RTHC-16	RHS-16	TMM-OR	FK2	RV-M
SB115200-000	240	1500	RESB1152	RTB	RTBSB	RTHC2-16	RHS2-16	TMM-OR	FK2	RV-M
SB115700-000	277	1500	RESB1157	RTB	RTBSB	RTHC-16	RHS-16	TMM-OR	FK2	RV-M
SB120100-000	120	2000	RESB1201	RTB	RTBSB	RTHC1-14	RHS1-14	TMM-OR	FK2	RV-M
SB120800-000	208	2000	RESB1208	RTB	RTBSB	RTHC-16	RHS-16	TMM-OR	FK2	RV-M
SB120200-000	240	2000	RESB1202	RTB	RTBSB	RTHC2-16	RHS2-16	TMM-OR	FK2	RV-M
SB122100-000	120	2250	RESB1221	RTB	RTBSB	RTHC1-14	RHS1-14	TMM-OR	FK2	RV-M
SB125800-000	208	2500	RECB1258	RTB	RTBSB	RTHC-16	RHS-16	TMM-OR	FK2	RV-M
SB125200-000	240	2500	RECB1252	RTB	RTBSB	RTHC2-16	RHS2-16	TMM-OR	FK2	RV-M
SB125700-000	277	2500	RECB1257	RTB	RTBSB	RTHC-16	RHS-16	TMM-OR	FK2	RV-M
SL130100-000	120	3000	RESL1301	RTL	RTBSL	N/A	N/A	TML-OR	FK6	RV-M
SL130800-000	208	3000	RESL1308	RTL	RTBSL	RTHC-16	RHS-16	TML-OR	FK6	RV-M
SL130200-000	240	3000	RESL1302	RTL	RTBSL	RTHC2-16	RHS2-16	TML-OR	FK6	RV-M
SL130700-000	277	3000	RESL1307	RTL	RTBSL	RTHC-16	RHS-16	TML-OR	FK6	RV-M
SL140800-000	208	4000	RESL1408	RTL	RTBSL	RTHC-14	RHS-14	TML-OR	FK6	RV-M
SL140200-000	240	4000	RESL1402	RTL	RTBSL	RTHC2-16	RHS2-14	TML-OR	FK6	RV-M
SL140700-000	277	4000	RESL1407	RTL	RTBSL	RTHC-16	RHS-16	TML-OR	FK6	RV-M

*Order this replacement cord if original heater is configured with a thermostat assembly.

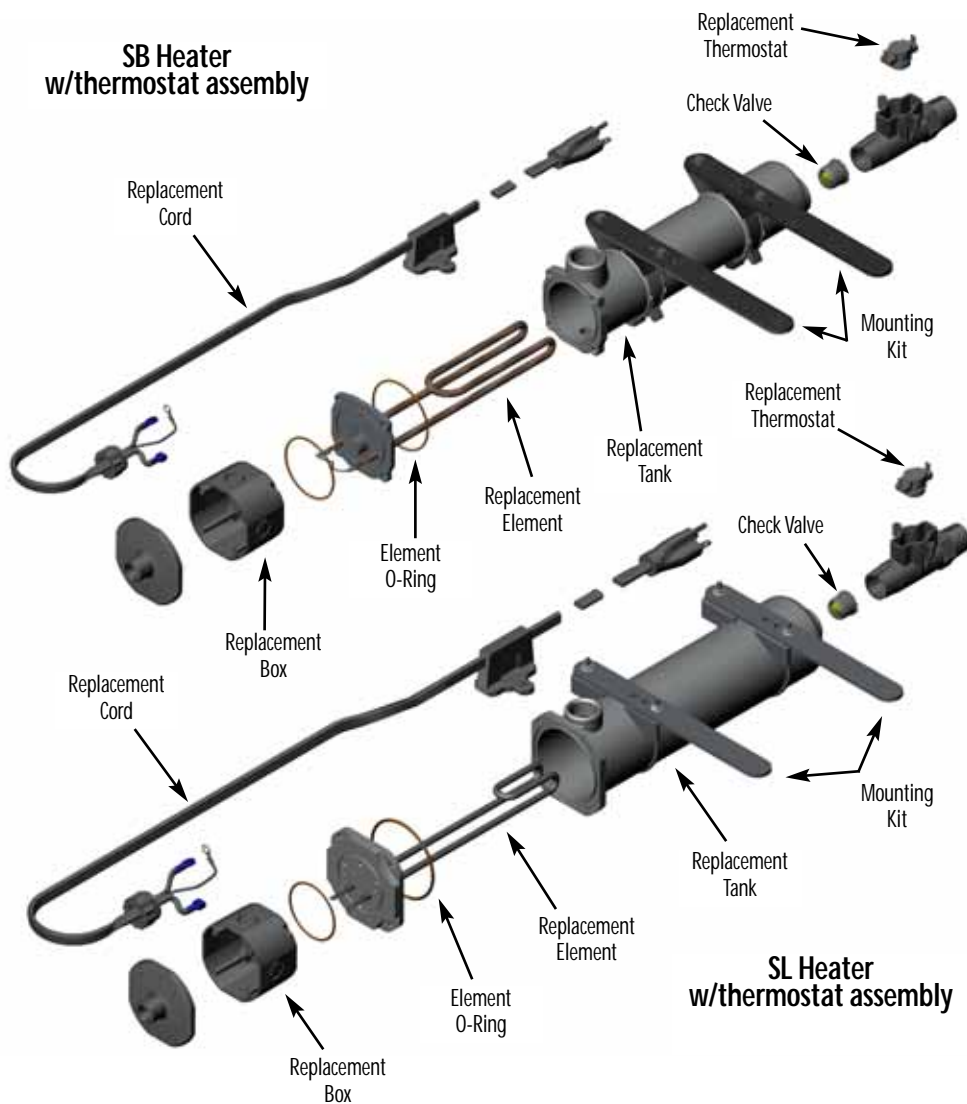

Heaters with Thermostats		
Temperature Range		Thermostat Replacement
ON	OFF	
60°F	80°F	RSU6
80°F	100°F	RSU8
100°F	120°F	RSU10
120°F	140°F	RSU12
140°F	160°F	RSU14
Adjustable 90° - 130°F		RSU90-130

Industrial Tank Heaters

1500 - 5000 watt
Weathertight
Three Phase



WL Model without thermostat



WL Model with thermostat



Ambient Above -20° F	Ambient Below -20° F	Model Number without Thermostat	Model Number with Thermostat (see chart 1)	Volts	Watts	Ø	Amp	Fig.* No.
500 Cubic Inch or Less	300 Cubic Inch or Less	WL315800-000	WL3158XX-000	208	1500	3	4.2	5
		WL315200-000	WL3152XX-000	240	1500	3	3.6	5
		WL315400-000	WL3154XX-000	480	1500	3	1.8	5
500 — 600 Cubic Inch or Less	300 — 400 Cubic Inch or Less	WL320800-000	WL3208XX-000	208	2000	3	5.6	5
		WL320200-000	WL3202XX-000	240	2000	3	4.8	5
		WL320300-000	WL3203XX-000	380	2000	3	3.0	5
		WL320400-000	WL3204XX-000	480	2000	3	2.4	5
		WL320500-000	WL3205XX-000	575	2000	3	2.0	5
600 — 800 Cubic Inch or Less	400 — 500 Cubic Inch or Less	WL325800-000	WL3258XX-000	208	2500	3	6.9	5
		WL325200-000	WL3252XX-000	240	2500	3	6.0	5
		WL325300-000	WL3253XX-000	380	2500	3	3.8	5
		WL325400-000	WL3254XX-000	480	2500	3	3.0	5
		WL325500-000	WL3255XX-000	575	2500	3	2.5	5
800 — 1000 Cubic Inch or Less	500 — 600 Cubic Inch or Less	WL330800-000	WL3308XX-000	208	3000	3	8.3	5
		WL330200-000	WL3302XX-000	240	3000	3	7.2	5
		WL330300-000	WL3303XX-000	380	3000	3	4.6	5
		WL330400-000	WL3304XX-000	480	3000	3	3.6	5
		WL330500-000	WL3305XX-000	575	3000	3	3.0	5
1000 — 1350 Cubic Inch or Less	600 — 800 Cubic Inch or Less	WL340800-000	WL3408XX-000	208	4000	3	11.1	5
		WL340200-000	WL3402XX-000	240	4000	3	9.6	5
		WL340300-000	WL3403XX-000	380	4000	3	6.1	5
		WL340400-000	WL3404XX-000	480	4000	3	4.8	5
		WL340500-000	WL3405XX-000	575	4000	3	4.0	5
1350 — 1650 Cubic Inch or Less	800 — 1000 Cubic Inch or Less	WL350800-000	WL3508XX-000	208	5000	3	13.9	5
		WL350200-000	WL3502XX-000	240	5000	3	12.0	5
		WL350300-000	WL3503XX-000	380	5000	3	7.6	5
		WL350400-000	WL3504XX-000	480	5000	3	6.0	5
		WL350500-000	WL3505XX-000	575	5000	3	5.0	5

*Figure Number refers to technical drawings of heaters located on page 14.

INSTALLATION TIPS	
If you require a 1" NPT female thread on the thermostat intake, a coupler is available. Also, for the use of 3/4" or 1" ID heater hose, hose barb adapters are available. See below.	
Part Number	Description
HB-1	1" NPT to 1" hose barb adapter. Installs in 1" NPT female inlet or outlet of the heater.
HB-3/4	1" NPT to 3/4" hose barb adapter. Installs in 1" NPT female inlet or outlet of the heater.
HB-C	1" NPT x 1" NPT aluminum coupler. Installs on 1" NPT inlet to T-Stat and allows the addition of HB-1 or HB-3/4.
HB-K3/4	Kit contains (2) HB-3/4 and (1) HB-C
HB-K1	Kit contains (2) HB-1 and (1) HB-C

CHART 1			
HEATERS WITH THERMOSTATS			
To specify temperature range of thermostat, insert numerical code from chart in place of the XX in model number.			
Example:			
Desired Temperature Range 100° - 120°F			
Catalog Number: Model WL3152XX-000			
Order as: Model WL315210-000			
All heaters over 277v and all 3Ø units must use a control box	TEMPERATURE RANGE		NUMERICAL CODE
	ON	OFF	
See Control Systems page 38	60°F	80°F	06
	80°F	100°F	08
	100°F	120°F	10
	120°F	140°F	12
	140°F	160°F	14
Adjustable 90° - 130°F		A3	

Replacement Parts

For tank-style heaters shown on page 12

Model Number	Volts	Watts	Replaceable Parts				
			Element	Tank	Element O-ring	Mounting Kit	Check Valve
WL315800-000	208	1500	E01583W-15NT-00	RTL	TML-OR	FK6	RV-M
WL315200-000	240	1500	E01523W-15NT-00	RTL	TML-OR	FK6	RV-M
WL315400-000	480	1500	E01543W-15NT-00	RTL	TML-OR	FK6	RV-M
WL320800-000	208	2000	E02083W-25NT-00	RTL	TML-OR	FK6	RV-M
WL320200-000	240	2000	E02023W-25NT-00	RTL	TML-OR	FK6	RV-M
WL320300-000	380	2000	E02033W-25NT-00	RTL	TML-OR	FK6	RV-M
WL320400-000	480	2000	E02043W-25NT-00	RTL	TML-OR	FK6	RV-M
WL320500-000	575	2000	E02053W-25NT-00	RTL	TML-OR	FK6	RV-M
WL325800-000	208	2500	E02583W-30NT-00	RTL	TML-OR	FK6	RV-M
WL325200-000	240	2500	E02523W-30NT-00	RTL	TML-OR	FK6	RV-M
WL325300-000	380	2500	E02533W-30NT-00	RTL	TML-OR	FK6	RV-M
WL325400-000	480	2500	E02543W-30NT-00	RTL	TML-OR	FK6	RV-M
WL325500-000	575	2500	E02553W-30NT-00	RTL	TML-OR	FK6	RV-M
WL330800-000	208	3000	E03083W-30NT-00	RTL	TML-OR	FK6	RV-M
WL330200-000	240	3000	E03023W-30NT-00	RTL	TML-OR	FK6	RV-M
WL330300-000	380	3000	E03033W-30NT-00	RTL	TML-OR	FK6	RV-M
WL330400-000	480	3000	E03043W-30NT-00	RTL	TML-OR	FK6	RV-M
WL330500-000	575	3000	E03053W-30NT-00	RTL	TML-OR	FK6	RV-M
WL340800-000	208	4000	E04083W-50NT-00	RTL	TML-OR	FK6	RV-M
WL340200-000	240	4000	E04023W-50NT-00	RTL	TML-OR	FK6	RV-M
WL340300-000	380	4000	E04033W-50NT-00	RTL	TML-OR	FK6	RV-M
WL340400-000	480	4000	E04043W-50NT-00	RTL	TML-OR	FK6	RV-M
WL340500-000	575	4000	E04053W-50NT-00	RTL	TML-OR	FK6	RV-M
WL350800-000	208	5000	E05083W-50NT-00	RTL	TML-OR	FK6	RV-M
WL350200-000	240	5000	E05023W-50NT-00	RTL	TML-OR	FK6	RV-M
WL350300-000	380	5000	E05033W-50NT-00	RTL	TML-OR	FK6	RV-M
WL350400-000	480	5000	E05043W-50NT-00	RTL	TML-OR	FK6	RV-M
WL350500-000	575	5000	E05053W-50NT-00	RTL	TML-OR	FK6	RV-M

WL Heater w/thermostat assembly

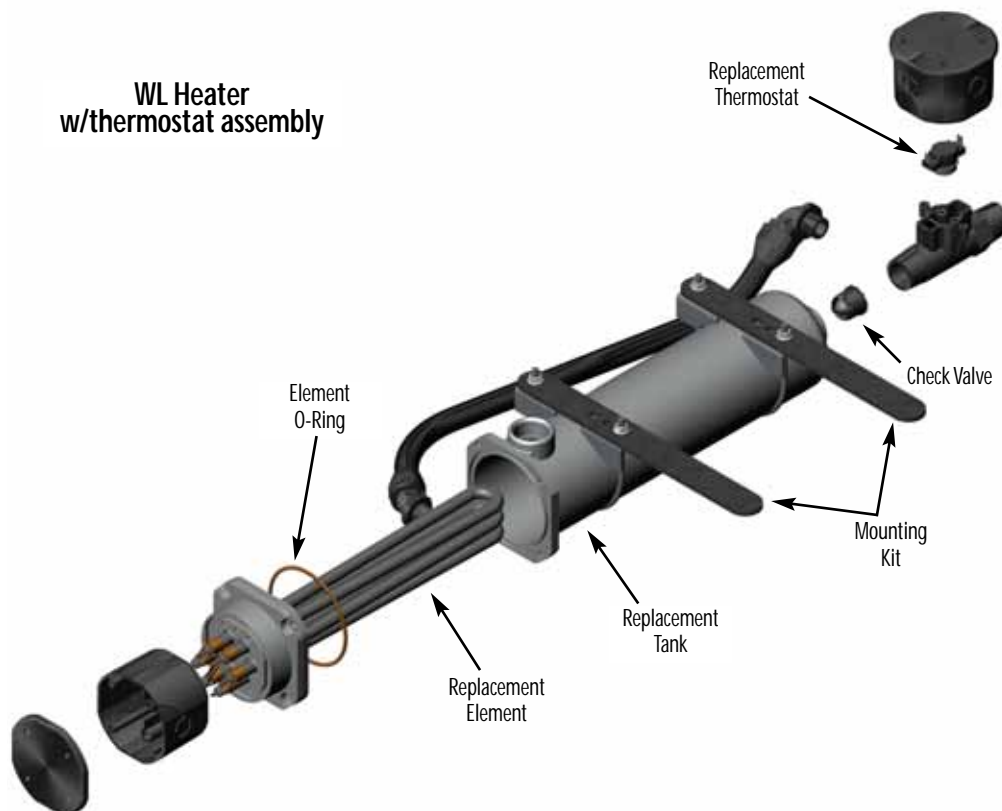

Heaters with Thermostats		
Temperature Range		Thermostat Replacement
ON	OFF	
60°F	80°F	RSU6
80°F	100°F	RSU8
100°F	120°F	RSU10
120°F	140°F	RSU12
140°F	160°F	RSU14
Adjustable 90° - 130°F		RSU90-130

Technical Drawings

all dimensions in inches

CB Style Heater without thermostat (pg. 8-9)

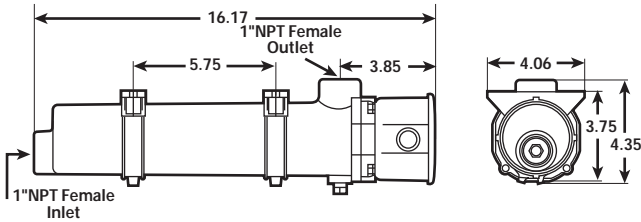
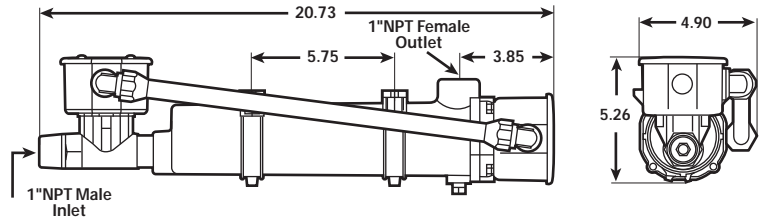

FIGURE 1

CB Style Heater with thermostat (pg. 8-9)



SB Style Heater without thermostat (pg. 10-11)

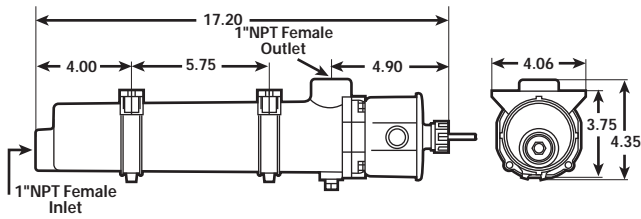
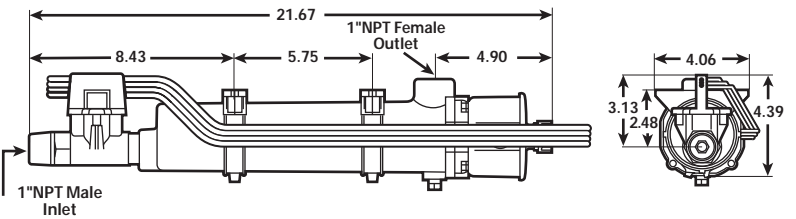

FIGURE 2

SB Style Heater with thermostat (pg. 10-11)



CL Style Heater without thermostat (pg. 8-9)

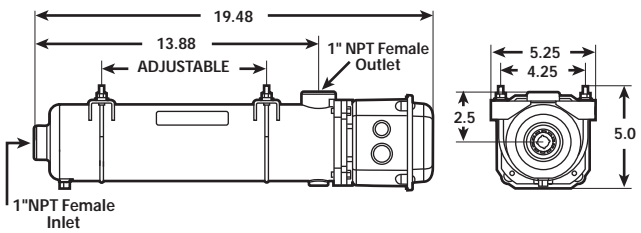
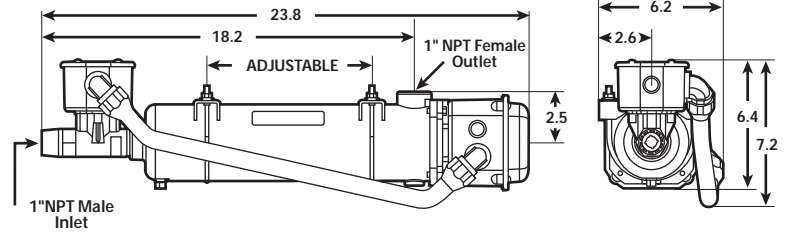

FIGURE 3

CL Style Heater with thermostat (pg. 8-9)



SL Style Heater without thermostat (pg. 10-11)

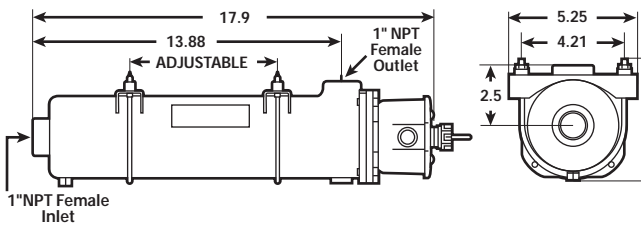
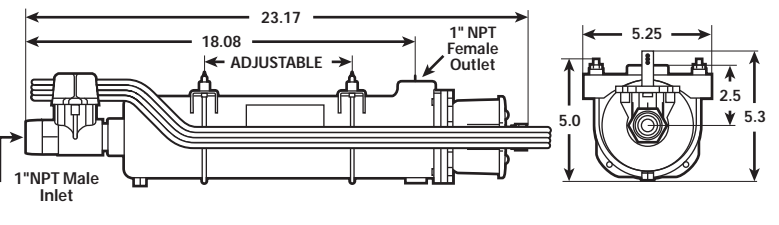

FIGURE 4

SL Style Heater with thermostat (pg. 10-11)



WL Style Heater without thermostat (pg. 12-13)

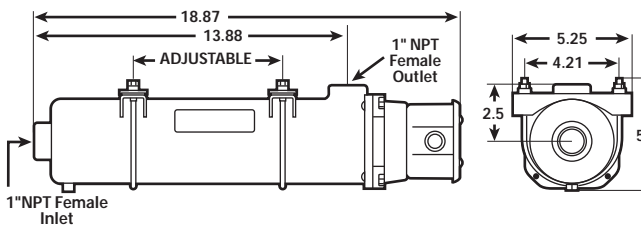
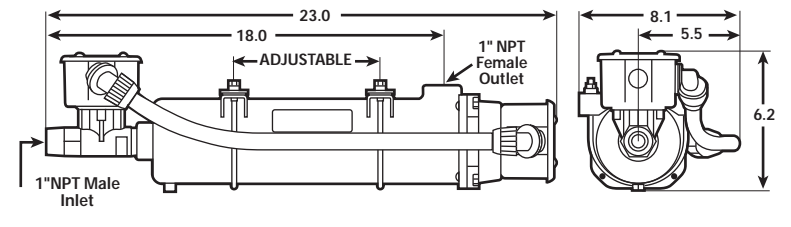

FIGURE 5

WL Style Heater with thermostat (pg. 12-13)



- Large NEMA 4 enclosure with 1/2" and 3/4" knockouts.
- Rubber insulating sleeve around tank.
- Internal adjustable thermostat. Adjustable setpoints from 70°F - 210°F.
- Incoloy sheath elements.
- Four wattage/voltage options. Three corresponding to Caterpillar part numbers.
- Vertical mount only.

For Original Equipment Replacement:

- Two 5" stainless steel worm-drive clamps are included to mount heater to existing bracket.

For New Installations:

- U-bolt mounting brackets are available. Order kit part number: **FK9**.

HOTSTART Part Number	Caterpillar Part Number	Wattage	Voltage	Pre-wired at Assembly	Replacement Element
CL130DA2-000	7E-6247	3kw	120/240 VAC	120V	RECL130D
CL160EA2-000	7E-6248*	6kw	240/480 VAC	240V	RECL160E
CL160CA2-000	7E-6249	6kw	120 VAC	2-120V Circuits	RECL160C
CL140EA2-000	—	4kw	240/480 VAC	240V	RECL140E

* Part Number changed to **2006504**

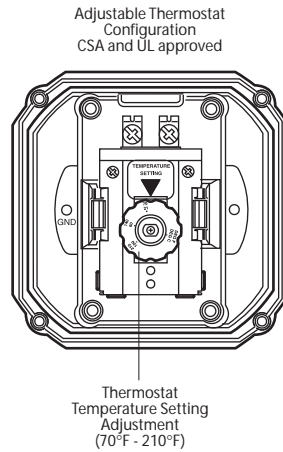
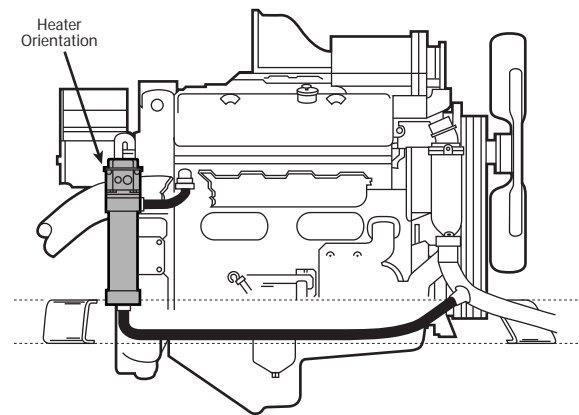

Industrial Tank Heaters

Original Equipment Replacement Heaters



Forced Circulating Heating System

With 10 GPM Pump

CSM Model

For Engines From 1000 to 6000 CID

These systems have proven to be a superior method of preheating engines that normally require the use of two thermosiphon heaters.

Forced circulation offers many benefits over thermosiphon units.

- Reduced electrical consumption
- Even heating over entire cooling system
- Reduced temperature at outlet extends hose life
- Longer heating element life
- Control circuitry pre-wired for easy installation

- UL-C/US listed (60Hz models) and CE compliant (50Hz models).
- 90°-130°F/32°-55°C adjustable thermostat.
- Small, compact design for easy installation.
- Meets requirements for installation on any UL 2200 listed generator

Engine Size		Part Number	Wattage	Voltage	Phase	Hz	Amps
CID	Liter						
1000 to 2000	15-30	CSM10301-000	3000	120	1	60	27.0
		CSM10308-000	3000	208	1	60	16.4
		CSM1030C-000	3000	220	1	50	15.6
		CSM10302-000	3000	240	1	60	14.5
2000 to 3000	25-50	CSM10608-000	6000	208	1	60	30.8
		CSM1060C-000	6000	220	1	50	29.3
		CSM10602-000	6000	240	1	60	27.0
		CSM10604-000	6000	480	1	60	14.5
		CSM30603-000	6000	380	3	50	11.1
		CSM30604-000	6000	480	3	60	9.2
3000 to 4500	50-75	CSM10908-000	9000	208	1	60	45.3
		CSM1090C-000	9000	220	1	50	42.9
		CSM10902-000	9000	240	1	60	39.5
		CSM10904-000	9000	480	1	60	20.8
		CSM30903-000	9000	380	3	50	15.7
		CSM30904-000	9000	480	3	60	12.8
4500 to 6000	75-100	CSM11202-000	12000	240	1	60	52.0
		CSM11204-000	12000	480	1	60	27.0
		CSM31203-000	12000	380	3	50	20.3
		CSM31204-000	12000	480	3	60	16.5

Other voltages available. Consult the factory.



The CSM operates automatically by supplying a 24 Volt DC signal to the provided contacts.

Field testing has shown substantial energy savings in comparison to traditional thermosiphon heating methods.

System Drawings

CSM Dimensions

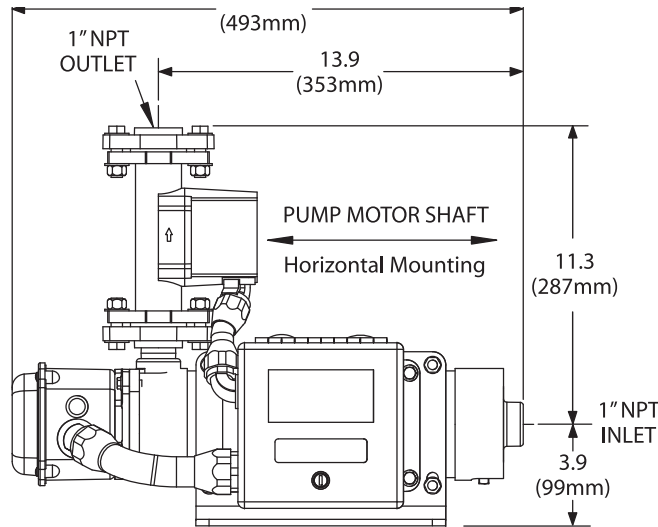
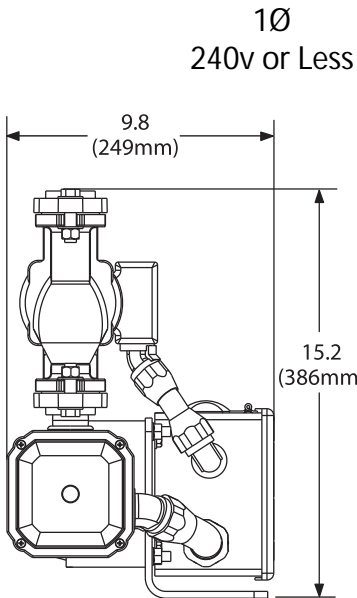

Shipping Weight: 37lbs. (16.8kg)

1Ø or 3Ø
Over 240v

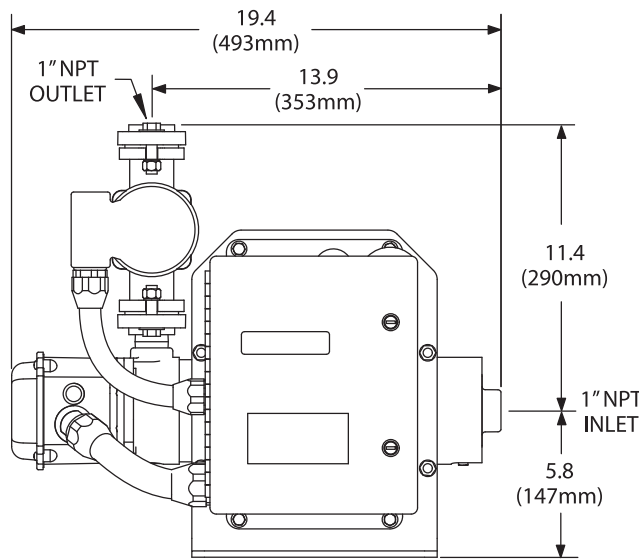
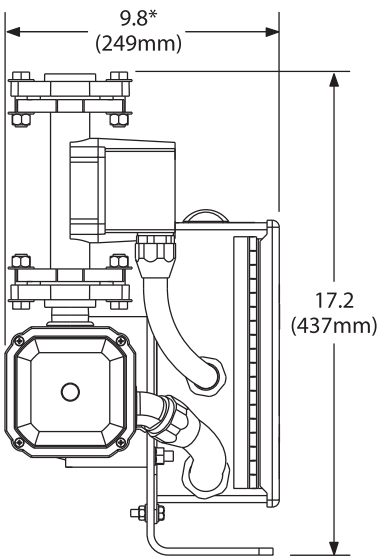

Shipping Weight: 54lbs. (24.5kg)

* For CE compliant models, overall depth measures 10.8" (274mm)

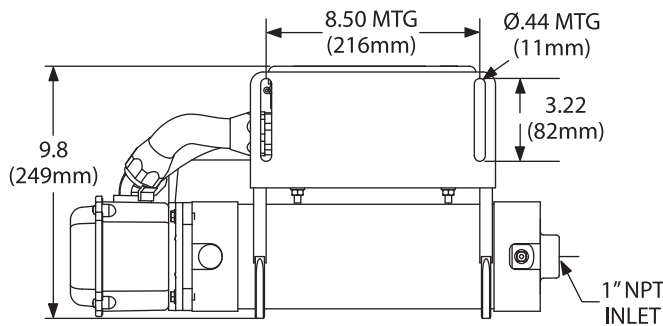

Section 2

*Industrial Tank Style
Coolant Heaters*

Hazardous Location



Industrial Tank Heaters

1500 - 5000 watt
Hazardous Location
Single Phase

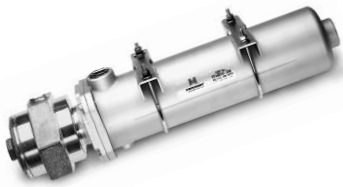

EE Model without thermostat.



EE Model assembled with thermostat.

Ambient Above -20° F	Ambient Below -20° F	Model Number without Thermostat	Fig.* No.	Model Number with Thermostat (see chart 1)	Fig.* No.	Volt	Watt	Ø	Amp
500 Cubic Inch or Less	300 Cubic Inch or Less	EE115100-000	1	EE1151XX-000	2	120	1500	1	12.5
		EE115800-000	1	EE1158XX-000	2	208	1500	1	7.2
		EE115200-000	1	EE1152XX-000	2	240	1500	1	6.3
		EE115700-000	1	EE1157XX-000	2	277	1500	1	5.4
		EE115300-000	1	EE1153XX-000	2	380	1500	1	3.9
		EE115400-000	1	EE1154XX-000	2	480	1500	1	3.1
		EE115500-000	1	EE1155XX-000	2	575	1500	1	2.6
500 - 600 Cubic Inch or Less	300 - 400 Cubic Inch or Less	EE120100-000	1	EE1201XX-000	2	120	2000	1	16.7
		EE120800-000	1	EE1208XX-000	2	208	2000	1	9.6
		EE120200-000	1	EE1202XX-000	2	240	2000	1	8.3
		EE120300-000	1	EE1203XX-000	2	380	2000	1	5.3
		EE120400-000	1	EE1204XX-000	2	480	2000	1	4.2
		EE120500-000	1	EE1205XX-000	2	575	2000	1	3.5
600 - 800 Cubic Inch or Less	400 - 500 Cubic Inch or Less	EE125100-000	1	EE1251XX-000	2	120	2500	1	20.8
		EE125800-000	1	EE1258XX-000	2	208	2500	1	12.0
		EE125200-000	1	EE1252XX-000	2	240	2500	1	10.4
		EE125700-000	1	EE1257XX-000	2	277	2500	1	9.2
		EE125300-000	1	EE1253XX-000	2	380	2500	1	6.6
		EE125400-000	1	EE1254XX-000	2	480	2500	1	5.2
		EE125500-000	1	EE1255XX-000	2	575	2500	1	4.3
800 - 1000 Cubic Inch or Less	500 - 600 Cubic Inch or Less	EE130100-000	1	EE1301XX-000	2	120	3000	1	25.0
		EE130800-000	1	EE1308XX-000	2	208	3000	1	14.4
		EE130200-000	1	EE1302XX-000	2	240	3000	1	12.5
		EE130700-000	1	EE1307XX-000	2	277	3000	1	10.8
		EE130300-000	1	EE1303XX-000	2	380	3000	1	7.9
		EE130400-000	1	EE1304XX-000	2	480	3000	1	6.3
		EE130500-000	1	EE1305XX-000	2	575	3000	1	5.2
1000 - 1350 Cubic Inch or Less	600 - 800 Cubic Inch or Less	EE140800-000	1	EE1408XX-000	2	208	4000	1	19.2
		EE140200-000	1	EE1402XX-000	2	240	4000	1	16.7
		EE140700-000	1	EE1407XX-000	2	277	4000	1	14.4
		EE140300-000	1	EE1403XX-000	2	380	4000	1	10.5
		EE140400-000	1	EE1404XX-000	2	480	4000	1	8.3
		EE140500-000	1	EE1405XX-000	2	575	4000	1	7.0
1350 - 1650 Cubic Inch or Less	800 - 1000 Cubic Inch or Less	EE150800-000	1	EE1508XX-000	2	208	5000	1	24.0
		EE150200-000	1	EE1502XX-000	2	240	5000	1	20.8
		EE150700-000	1	EE1507XX-000	2	277	5000	1	18.1
		EE150300-000	1	EE1503XX-000	2	380	5000	1	13.2
		EE150400-000	1	EE1504XX-000	2	480	5000	1	10.4
		EE150500-000	1	EE1505XX-000	2	575	5000	1	8.7

*Figure Number refers to technical drawings of heaters located on page 24.

INSTALLATION TIPS	
For the use of 3/4" or 1" ID heater hose, hose barb adapters are available. See below.	
Part Number	Description
HB-1	1" NPT to 1" hose barb adapter. Installs in 1" NPT female inlet or outlet of the heater.
HB-3/4	1" NPT to 3/4" hose barb adapter. Installs in 1" NPT female inlet or outlet of the heater.

CHART 1			
HEATERS WITH THERMOSTATS			
To specify temperature range of thermostat, insert numerical code from chart in place of the XX in model number.			
Example:			
Desired Temperature Range 100° - 120°F			
Catalog Number: Model EE1151XX-000			
Order as: Model EE115110-000			
All heaters over 277v and all 3Ø units must use a control box See Control Systems page 38	TEMPERATURE RANGE		NUMERICAL CODE
	ON	OFF	
	60°F	80°F	06
	80°F	100°F	08
	100°F	120°F	10
120°F	140°F	12	
140°F	160°F	14	

Replacement Parts

For tank-style heaters shown on page 20

Model Number	Volts	Watts	Replaceable Parts						
			Element	MI Cable	Tank	Flange	Flange O-ring	Mount Kit	Check Valve
EE115100-000	120	1500	REEE1151	PRP104202-024	RTL	RF-L	TML-OR	FK6	RV-M
EE115800-000	208	1500	REEE1158	PRP104202-024	RTL	RF-L	TML-OR	FK6	RV-M
EE115200-000	240	1500	REEE1152	PRP104202-024	RTL	RF-L	TML-OR	FK6	RV-M
EE115700-000	277	1500	REEE1157	PRP104202-024	RTL	RF-L	TML-OR	FK6	RV-M
EE115300-000	380	1500	E01531E-50NA-00	PRP104202-024	RTL	RF-L	TML-OR	FK6	RV-M
EE115400-000	480	1500	E01541E-50NA-00	PRP104202-024	RTL	RF-L	TML-OR	FK6	RV-M
EE115500-000	575	1500	E01551E-50NA-00	PRP104202-024	RTL	RF-L	TML-OR	FK6	RV-M
EE120100-000	120	2000	REEE1201	PRP104202-024	RTL	RF-L	TML-OR	FK6	RV-M
EE120800-000	208	2000	REEE1208	PRP104202-024	RTL	RF-L	TML-OR	FK6	RV-M
EE120200-000	240	2000	REEE1202	PRP104202-024	RTL	RF-L	TML-OR	FK6	RV-M
EE120300-000	380	2000	E02031E-50NA-00	PRP104202-024	RTL	RF-L	TML-OR	FK6	RV-M
EE120400-000	480	2000	E02041E-50NA-00	PRP104202-024	RTL	RF-L	TML-OR	FK6	RV-M
EE120500-000	575	2000	E02051E-50NA-00	PRP104202-024	RTL	RF-L	TML-OR	FK6	RV-M
EE125100-000	120	2500	REEE1251	PRP104202-024	RTL	RF-L	TML-OR	FK6	RV-M
EE125800-000	208	2500	REEE1258	PRP104202-024	RTL	RF-L	TML-OR	FK6	RV-M
EE125200-000	240	2500	REEE1252	PRP104202-024	RTL	RF-L	TML-OR	FK6	RV-M
EE125700-000	277	2500	REEE1257	PRP104202-024	RTL	RF-L	TML-OR	FK6	RV-M
EE125300-000	380	2500	E02531E-C0NA-00	PRP104202-024	RTL	RF-L	TML-OR	FK6	RV-M
EE125400-000	480	2500	E02541E-C0NA-00	PRP104202-024	RTL	RF-L	TML-OR	FK6	RV-M
EE125500-000	575	2500	E02551E-C0NA-00	PRP104202-024	RTL	RF-L	TML-OR	FK6	RV-M
EE130100-000	120	3000	REEE1301	PRP104202-024	RTL	RF-L	TML-OR	FK6	RV-M
EE130800-000	208	3000	REEE1308	PRP104202-024	RTL	RF-L	TML-OR	FK6	RV-M
EE130200-000	240	3000	REEE1302	PRP104202-024	RTL	RF-L	TML-OR	FK6	RV-M
EE130700-000	277	3000	REEE1307	PRP104202-024	RTL	RF-L	TML-OR	FK6	RV-M
EE130300-000	380	3000	E03031E-50NA-00	PRP104202-024	RTL	RF-L	TML-OR	FK6	RV-M
EE130400-000	480	3000	E03041E-50NA-00	PRP104202-024	RTL	RF-L	TML-OR	FK6	RV-M
EE130500-000	575	3000	E03051E-50NA-00	PRP104202-024	RTL	RF-L	TML-OR	FK6	RV-M
EE140800-000	208	4000	REEE1408	PRP104202-024	RTL	RF-L	TML-OR	FK6	RV-M
EE140200-000	240	4000	REEE1402	PRP104202-024	RTL	RF-L	TML-OR	FK6	RV-M
EE140700-000	277	4000	REEE1407	PRP104202-024	RTL	RF-L	TML-OR	FK6	RV-M
EE140300-000	380	4000	E04031E-50NA-00	PRP104202-024	RTL	RF-L	TML-OR	FK6	RV-M
EE140400-000	480	4000	E04041E-50NA-00	PRP104202-024	RTL	RF-L	TML-OR	FK6	RV-M
EE140500-000	575	4000	E04051E-50NA-00	PRP104202-024	RTL	RF-L	TML-OR	FK6	RV-M
EE150800-000	208	5000	E05081E-50NA-00	PRP104202-024	RTL	RF-L	TML-OR	FK6	RV-M
EE150200-000	240	5000	E05021E-50NA-00	PRP104202-024	RTL	RF-L	TML-OR	FK6	RV-M
EE150700-000	277	5000	E05071E-C0NA-00	PRP104202-024	RTL	RF-L	TML-OR	FK6	RV-M
EE150300-000	380	5000	E05031E-C0NA-00	PRP104202-024	RTL	RF-L	TML-OR	FK6	RV-M
EE150400-000	480	5000	E05041E-C0NA-00	PRP104202-024	RTL	RF-L	TML-OR	FK6	RV-M
EE150500-000	575	5000	E05051E-C0NA-00	PRP104202-024	RTL	RF-L	TML-OR	FK6	RV-M

EE Heater w/thermostat assembly

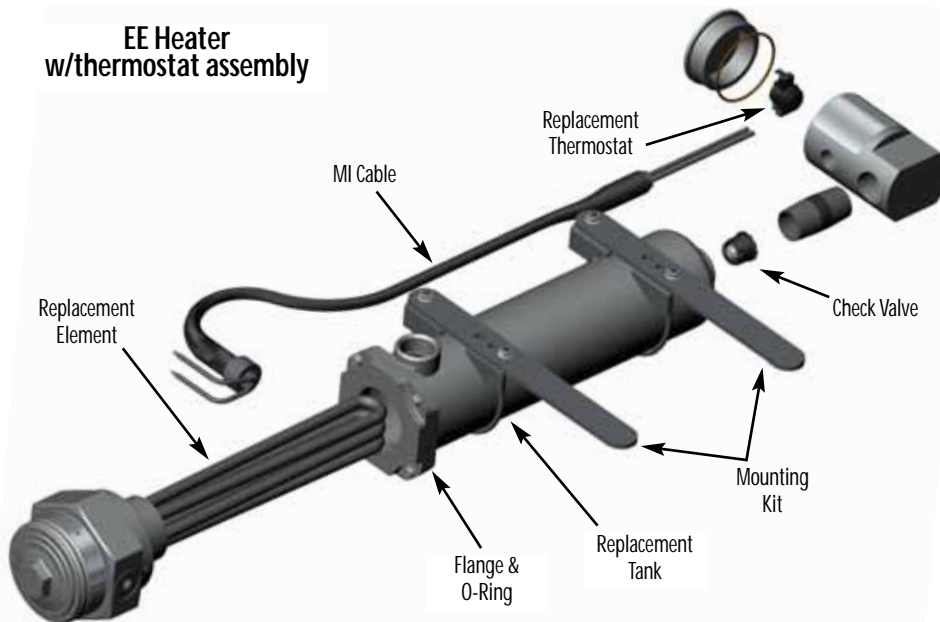

Heaters with Thermostats		
Temperature Range		Thermostat Replacement
ON	OFF	
60°F	80°F	RSU6
80°F	100°F	RSU8
100°F	120°F	RSU10
120°F	140°F	RSU12
140°F	160°F	RSU14

Industrial Tank Heaters

1500 - 5000 watt
Hazardous Location
Three Phase

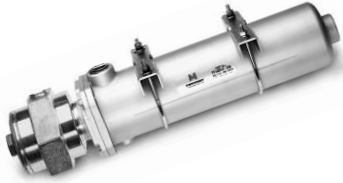

EE Model without thermostat.



EE Model assembled with thermostat.

Ambient Above -20° F	Ambient Below -20° F	Model Number without Thermostat	Fig.* No.	Model Number with Thermostat (see chart 1)	Fig.* No.	Volt	Watts	Ø	Amp
500 Cubic Inch or Less	300 Cubic Inch or Less	EE315800-000	1	EE3158XX-000	2	208	1500	3	4.2
		EE315200-000	1	EE3152XX-000	2	240	1500	3	3.6
		EE315400-000	1	EE3154XX-000	2	480	1500	3	1.8
500 - 600 Cubic Inch or Less	300 - 400 Cubic Inch or Less	EE320800-000	1	EE3208XX-000	2	208	2000	3	5.6
		EE320200-000	1	EE3202XX-000	2	240	2000	3	4.8
		EE320300-000	1	EE3203XX-000	2	380	2000	3	3.0
		EE320400-000	1	EE3204XX-000	2	480	2000	3	2.4
		EE320500-000	1	EE3205XX-000	2	575	2000	3	2.0
600 - 800 Cubic Inch or Less	400 - 500 Cubic Inch or Less	EE325800-000	1	EE3258XX-000	2	208	2500	3	6.9
		EE325200-000	1	EE3252XX-000	2	240	2500	3	6.0
		EE325300-000	1	EE3253XX-000	2	380	2500	3	3.8
		EE325400-000	1	EE3254XX-000	2	480	2500	3	3.0
		EE325500-000	1	EE3255XX-000	2	575	2500	3	2.5
800 - 1000 Cubic Inch or Less	500 - 600 Cubic Inch or Less	EE330800-000	1	EE3308XX-000	2	208	3000	3	8.3
		EE330200-000	1	EE3302XX-000	2	240	3000	3	7.2
		EE330300-000	1	EE3303XX-000	2	380	3000	3	4.6
		EE330400-000	1	EE3304XX-000	2	480	3000	3	3.6
		EE330500-000	1	EE3305XX-000	2	575	3000	3	3.0
1000 - 1350 Cubic Inch or Less	600 - 800 Cubic Inch or Less	EE340800-000	1	EE3408XX-000	2	208	4000	3	11.1
		EE340200-000	1	EE3402XX-000	2	240	4000	3	9.6
		EE340300-000	1	EE3403XX-000	2	380	4000	3	6.1
		EE340400-000	1	EE3404XX-000	2	480	4000	3	4.8
		EE340500-000	1	EE3405XX-000	2	575	4000	3	4.0
1350 - 1650 Cubic Inch or Less	800 - 1000 Cubic Inch or Less	EE350800-000	1	EE3508XX-000	2	208	5000	3	13.9
		EE350200-000	1	EE3502XX-000	2	240	5000	3	12.0
		EE350300-000	1	EE3503XX-000	2	380	5000	3	7.6
		EE350400-000	1	EE3504XX-000	2	480	5000	3	6.0
		EE350500-000	1	EE3505XX-000	2	575	5000	3	5.0

*Figure Number refers to technical drawings of heaters located on page 24.

INSTALLATION TIPS	
For the use of 3/4" or 1" ID heater hose, hose barb adapters are available. See below.	
Part Number	Description
HB-1	1" NPT to 1" hose barb adapter. Installs in 1" NPT female inlet or outlet of the heater.
HB-3/4	1" NPT to 3/4" hose barb adapter. Installs in 1" NPT female inlet or outlet of the heater.

CHART 1			
HEATERS WITH THERMOSTATS			
To specify temperature range of thermostat, insert numerical code from chart in place of the XX in model number.			
Example:			
Desired Temperature Range 100° - 120°F			
Catalog Number: Model EE3152XX-000			
Order as: Model EE315210-000			
All heaters over 277v and all 3Ø units must use a control box See Control Systems page 38	TEMPERATURE RANGE		NUMERICAL CODE
	ON	OFF	
	60°F	80°F	06
	80°F	100°F	08
	100°F	120°F	10
120°F	140°F	12	
140°F	160°F	14	

Replacement Parts

For tank-style heaters shown on page 22

Model Number	Volts	Watts	Replaceable Parts						
			Element	MI Cable	Tank	Flange	Flange O-ring	Mount Kit	Check Valve
EE315800-000	208	1500	E01583E-15NA-00	PRP104202-024	RTL	RF-L	TML-OR	FK6	RV-M
EE315200-000	240	1500	E01523E-15NA-00	PRP104202-024	RTL	RF-L	TML-OR	FK6	RV-M
EE315400-000	480	1500	E01543E-15NA-00	PRP104202-024	RTL	RF-L	TML-OR	FK6	RV-M
EE320800-000	208	2000	E02083E-25NA-00	PRP104202-024	RTL	RF-L	TML-OR	FK6	RV-M
EE320200-000	240	2000	E02023E-25NA-00	PRP104202-024	RTL	RF-L	TML-OR	FK6	RV-M
EE320300-000	380	2000	E02033E-25NA-00	PRP104202-024	RTL	RF-L	TML-OR	FK6	RV-M
EE320400-000	480	2000	E02043E-25NA-00	PRP104202-024	RTL	RF-L	TML-OR	FK6	RV-M
EE320500-000	575	2000	E02053E-25NA-00	PRP104202-024	RTL	RF-L	TML-OR	FK6	RV-M
EE325800-000	208	2500	E02583E-30NA-00	PRP104202-024	RTL	RF-L	TML-OR	FK6	RV-M
EE325200-000	240	2500	E02523E-30NA-00	PRP104202-024	RTL	RF-L	TML-OR	FK6	RV-M
EE325300-000	380	2500	E02533E-30NA-00	PRP104202-024	RTL	RF-L	TML-OR	FK6	RV-M
EE325400-000	480	2500	E02543E-30NA-00	PRP104202-024	RTL	RF-L	TML-OR	FK6	RV-M
EE325500-000	575	2500	E02553E-30NA-00	PRP104202-024	RTL	RF-L	TML-OR	FK6	RV-M
EE330800-000	208	3000	E03083E-30NA-00	PRP104202-024	RTL	RF-L	TML-OR	FK6	RV-M
EE330200-000	240	3000	E03023E-30NA-00	PRP104202-024	RTL	RF-L	TML-OR	FK6	RV-M
EE330300-000	380	3000	E03033E-30NA-00	PRP104202-024	RTL	RF-L	TML-OR	FK6	RV-M
EE330400-000	480	3000	E03043E-30NA-00	PRP104202-024	RTL	RF-L	TML-OR	FK6	RV-M
EE330500-000	575	3000	E03053E-30NA-00	PRP104202-024	RTL	RF-L	TML-OR	FK6	RV-M
EE340800-000	208	4000	E04083E-50NA-00	PRP104202-024	RTL	RF-L	TML-OR	FK6	RV-M
EE340200-000	240	4000	E04023E-50NA-00	PRP104202-024	RTL	RF-L	TML-OR	FK6	RV-M
EE340300-000	380	4000	E04033E-50NA-00	PRP104202-024	RTL	RF-L	TML-OR	FK6	RV-M
EE340400-000	480	4000	E04043E-50NA-00	PRP104202-024	RTL	RF-L	TML-OR	FK6	RV-M
EE340500-000	575	4000	E04053E-50NA-00	PRP104202-024	RTL	RF-L	TML-OR	FK6	RV-M
EE350800-000	208	5000	E05083E-50NA-00	PRP104202-024	RTL	RF-L	TML-OR	FK6	RV-M
EE350200-000	240	5000	E05023E-50NA-00	PRP104202-024	RTL	RF-L	TML-OR	FK6	RV-M
EE350300-000	380	5000	E05033E-50NA-00	PRP104202-024	RTL	RF-L	TML-OR	FK6	RV-M
EE350400-000	480	5000	E05043E-50NA-00	PRP104202-024	RTL	RF-L	TML-OR	FK6	RV-M
EE350500-000	575	5000	E05053E-50NA-00	PRP104202-024	RTL	RF-L	TML-OR	FK6	RV-M

EE Heater w/thermostat assembly

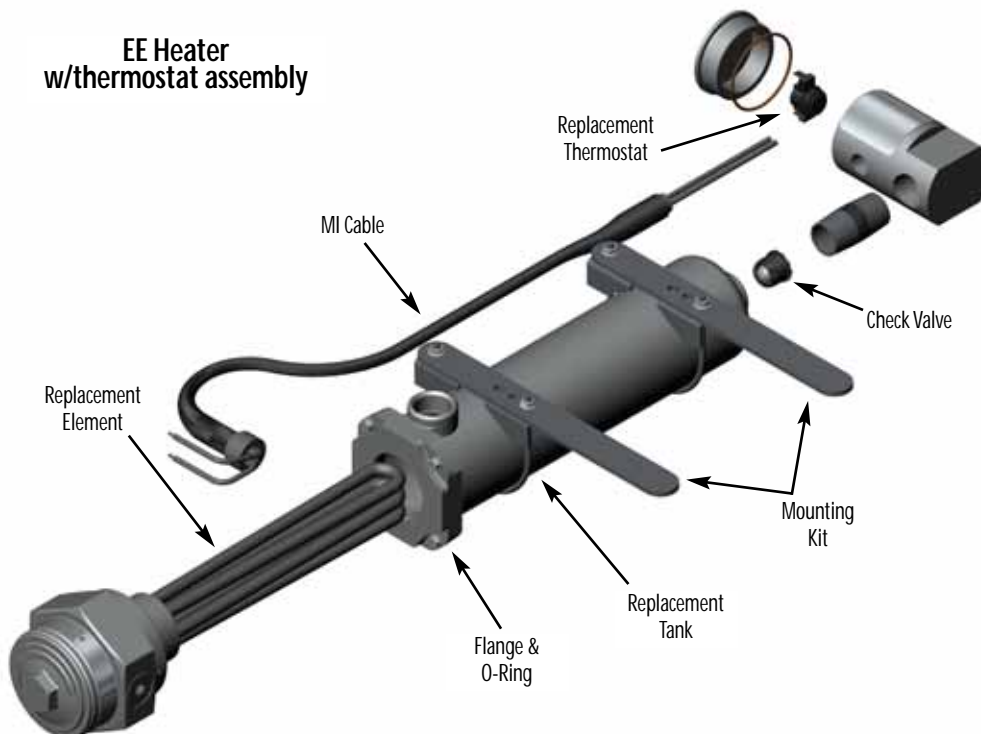

Heaters with Thermostats		
Temperature Range		Thermostat Replacement
ON	OFF	
60°F	80°F	RSU6
80°F	100°F	RSU8
100°F	120°F	RSU10
120°F	140°F	RSU12
140°F	160°F	RSU14

Technical Drawings

all dimensions in inches

FIGURE 1

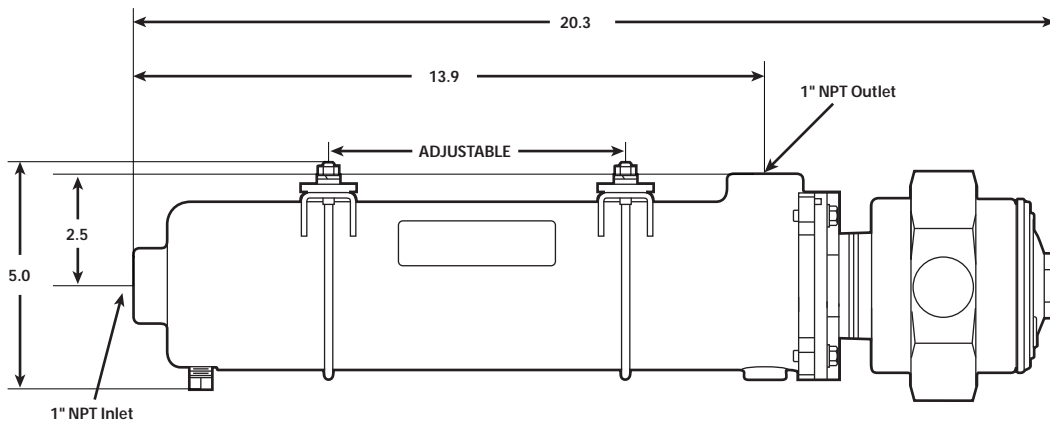

EE Style Heater without thermostat (pg. 20 and 22)

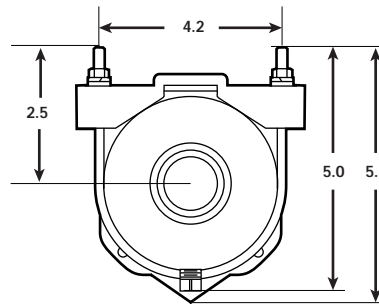
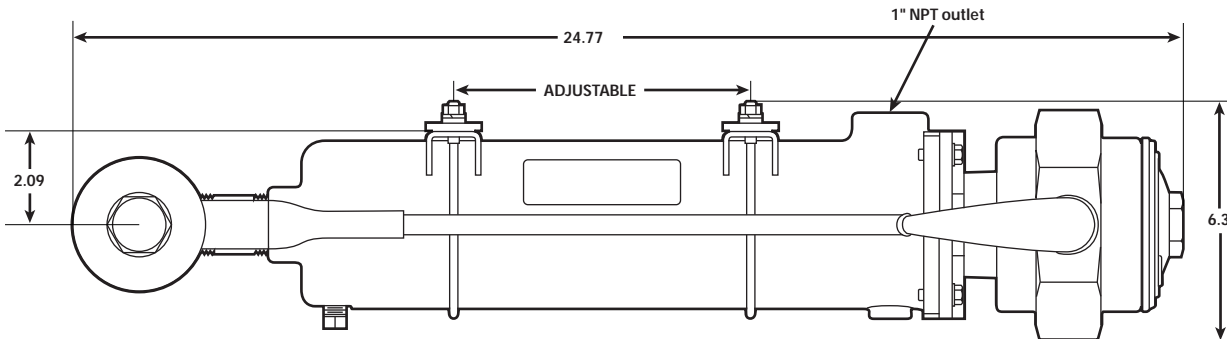
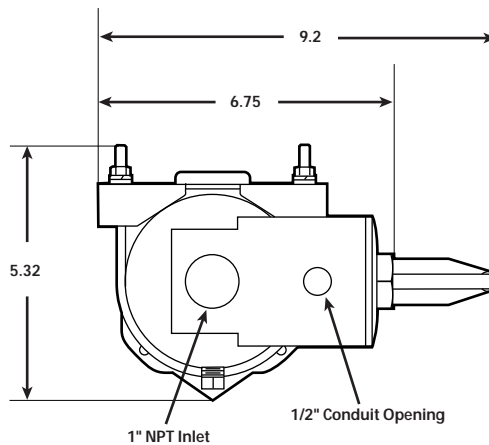

FIGURE 2



EE Style Heater with thermostat (pg. 20 and 22)



Section 3

Industrial Oil Heaters

Industrial Immersion Heaters – Thread-in style and threadless V-clamp style

DC Oil Heaters

Temperature Controls



Oil Heaters



Oil Capacity	Weathertight Heater Only	Weathertight With Thermostat (see chart p. 27)	Class 1, Group D Hazardous Locations Heater Only	Volts	Watts	Amps	Watts Per Square Inch
3/8" N.P.T. THREAD WITH A 2 1/8" PROBE LENGTH							
2 Quarts or Less	OW005100-000 OW005200-000	— —	— —	120 240	50 50	.4 .2	20.0 20.0
1/2" N.P.T. THREAD WITH A 4" PROBE LENGTH							
2 Quarts to 6 Quarts	OW212100-000 OW212200-000	OW2121XX-000 OW2122XX-000	OE212100-000 OE212200-000	120 240	125 125	1.0 .5	24.6 24.6
3/4" N.P.T. THREAD WITH A 5" PROBE LENGTH							
1 Gallon to 5 Gallons	OW415100-000 OW415200-000	OW4151XX-000 OW4152XX-000	OE415100-000 OE415200-000	120 240	150 150	1.3 .6	14.6 14.6
5 Gallons to 15 Gallons	OW430100-000 OW430800-000 OW430200-000	OW4301XX-000 OW4308XX-000 OW4302XX-000	OE430100-000 OE430800-000 OE430200-000	120 208 240	300 300 300	2.6 1.1 1.2	29.3 29.3 29.3
1" N.P.T. THREAD WITH A 5 1/4" PROBE LENGTH							
1 Gallon to 5 Gallons	OW615100-000 OW615200-000	OW6151XX-000 OW6152XX-000	OE615100-000 OE615200-000	120 240	150 150	1.3 .6	10.7 10.7
5 Gallons to 15 Gallons	OW630100-000 OW630800-000 OW630200-000 OW630700-000 — —	OW6301XX-000 OW6308XX-000 OW6302XX-000 OW6307XX-000 — —	OE630100-000 OE630800-000 OE630200-000 OE630700-000 OE630300-000 OE630400-000	120 208 240 277 380 480	300 300 300 300 300 300	2.6 1.6 1.2 1.1 1.0 .6	21.4 21.4 21.4 21.4 21.4 21.4
15 Gallons to 30 Gallons	OW650100-000 OW650800-000 OW650200-000 OW650700-000 — —	OW6501XX-000 OW6508XX-000 OW6502XX-000 OW6507XX-000 — —	OE650100-000 OE650800-000 OE650200-000 OE650700-000 OE650300-000 OE650400-000 OE650500-000	120 208 240 277 380 480 575	500 500 500 500 500 500 500	4.1 2.4 2.0 1.8 1.3 1.0 0.8	35.7 35.7 35.7 35.7 35.7 35.7 35.7

NOTES: Weathertight heaters are standard with a 4 ft. oil and heat resistant power cord - no plug.

Class 1, Group D heaters are standard with 18" of lead wire for connection to the power leads in an approved splice box.

For Class 1, Group D thermostats, see page 32.

heater only

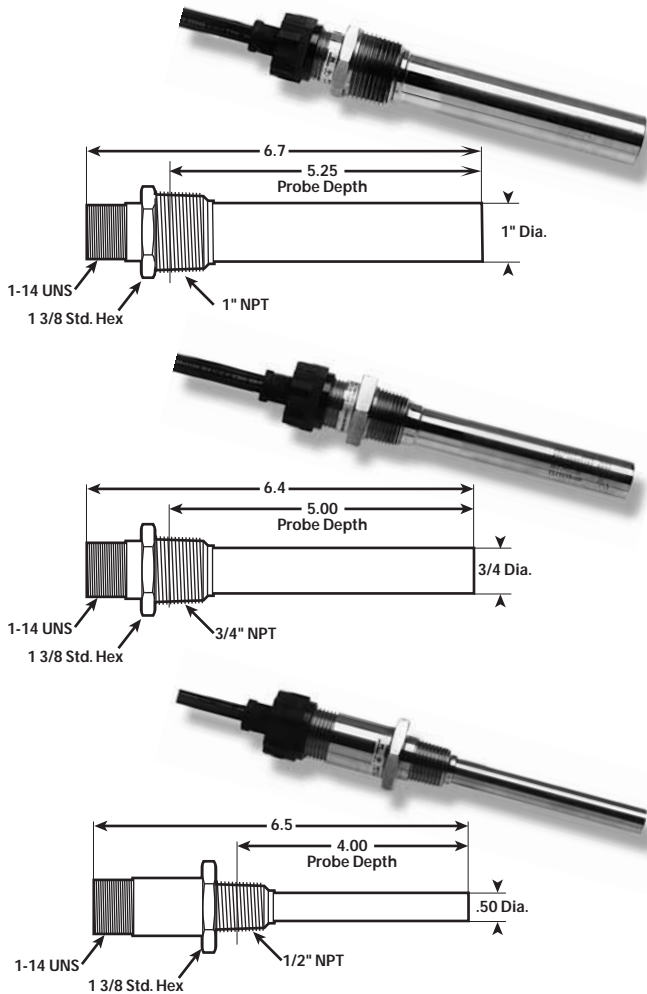

heater only

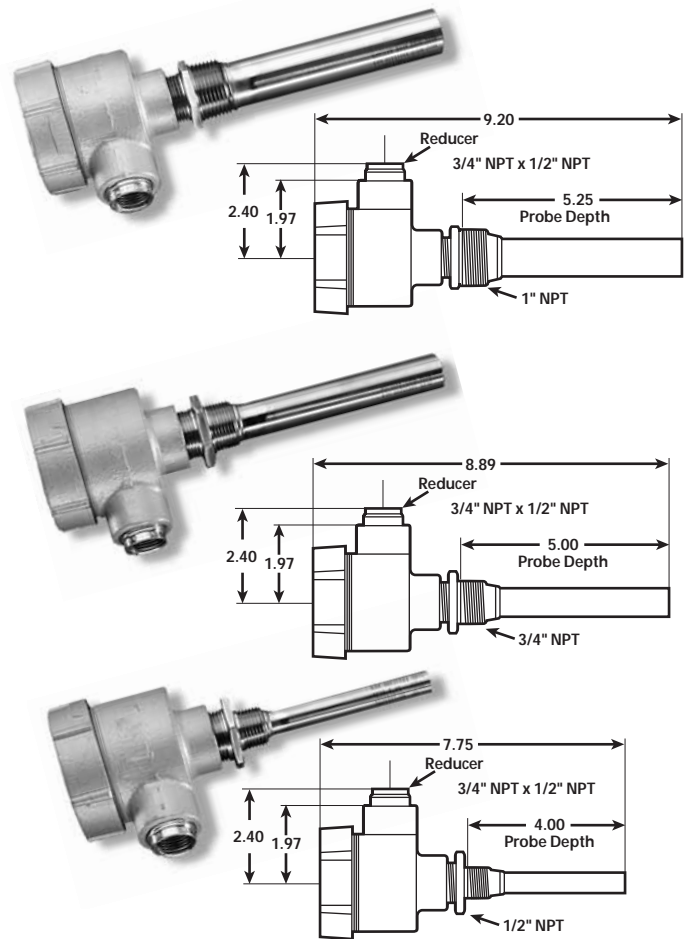

For Class 1, Group D thermostats, see page 32.

Heaters with Y-type harness and thermostat (see page 32 for drawings with dimensions)

Use a thermostat with all lube oil heaters to protect the oil from overheating if the heater is energized while the engine is hot or running.

Lube oil heaters must always be installed in the sump with the entire heater submerged below the oil level at all times.



120 Volt and 240 Volt are complete with a 3-prong plug.

HOTSTART Assembled Lube Oil Heaters eliminate the need for splice boxes or field wiring of the thermostat and heater.

Always mount the thermostat above and to one side of the heater for the most efficient control.

OIL HEATERS WITH THERMOSTATS

To specify temperature range of thermostat, insert numerical code from chart in place of the XX in model number.

Example:

Desired Temperature Range: 100° - 120°
 Catalog Number: Model OW2121XX-000
 Order as: Model OW212110-000

NUMERICAL CODE	TEMPERATURE RANGE		SWITCH CAPACITY	THREAD SIZE
	On	Off		
06	60°F	80°F	120V - 15 Amps	1/2" N.P.T.
08	80°F	100°F	208V - 10 Amps	
10	100°F	120°F	240V - 10 Amps	
12	120°F	140°F	277V - 10 Amps	

Industrial Immersion Heaters

For: Lube Oils,
Hydraulics and
Diesel Fuels

2" Screw Plug
With Fixed-Setting,
Built-In Thermostat (Pg. 29)
or Adjustable
Thermostat (Pg. 31)

**Weather Tight
NEMA 4 Enclosure**

Models for larger capacities than shown are available. Call factory.

Oil Capacity	HIGH LIMIT THERMOSTAT CONTROL SETTING			Volts	Watts	Amps	Watts Sq. In.
	On 60° F / Off 80° F	On 80° F / Off 100° F	On 100° F / Off 120° F				
SINGLE PHASE — 2" N.P.T. WITH A 12" PROBE LENGTH							
30 to 45 Gallons	E01011W-156A-00	E01011W-158A-00	E01011W-151A-00	120	1000	8.3	17.0
	E01081W-156A-00	E01081W-158A-00	E01081W-151A-00	208	1000	4.8	17.0
	E01021W-156A-00	E01021W-158A-00	E01021W-151A-00	240	1000	4.2	17.0
	E01071W-156A-00	E01071W-158A-00	E01071W-151A-00	277	1000	3.6	17.0
45 to 60 Gallons	E01511W-156A-00	E01511W-158A-00	E01511W-151A-00	120	1500	12.5	17.0
	E01581W-156A-00	E01581W-158A-00	E01581W-151A-00	208	1500	7.2	17.0
	E01521W-156A-00	E01521W-158A-00	E01521W-151A-00	240	1500	6.3	17.0
	E01571W-156A-00	E01571W-158A-00	E01571W-151A-00	277	1500	5.4	17.0
THREE PHASE — 2" N.P.T. WITH A 12" PROBE LENGTH							
30 to 45 Gallons	E01083W-106A-00	E01083W-108A-00	E01083W-101A-00	208	1000	2.8	11.0
	E01023W-106A-00	E01023W-108A-00	E01023W-101A-00	240	1000	2.4	11.0
	E01033W-106A-00	E01033W-108A-00	E01033W-101A-00	380	1000	1.5	11.0
45 to 60 Gallons	E01583W-156A-00	E01583W-158A-00	E01583W-151A-00	208	1500	4.2	17.0
	E01523W-156A-00	E01523W-158A-00	E01523W-151A-00	240	1500	3.6	17.0
	E01533W-156A-00	E01533W-158A-00	E01533W-151A-00	380	1500	2.3	17.0
	E01543W-156A-00	E01543W-158A-00	E01543W-151A-00	480	1500	1.8	17.0
SINGLE PHASE — 2" N.P.T. WITH A 18" PROBE LENGTH							
60 to 90 Gallons	E02011W-156A-00	E02011W-158A-00	E02011W-151A-00	120	2000	16.7	14.0
	E02081W-156A-00	E02081W-158A-00	E02081W-151A-00	208	2000	9.6	14.0
	E02021W-156A-00	E02021W-158A-00	E02021W-151A-00	240	2000	8.4	14.0
	E02071W-156A-00	E02071W-158A-00	E02071W-151A-00	277	2000	7.2	14.0
	E02031W-156A-00	E02031W-158A-00	E02031W-151A-00	380	2000	5.3	14.0
	E02041W-156A-00	E02041W-158A-00	E02041W-151A-00	480	2000	4.2	14.0
THREE PHASE — 2" N.P.T. WITH A 18" PROBE LENGTH							
60 to 90 Gallons	E02083W-156A-00	E02083W-158A-00	E02083W-151A-00	208	2000	5.6	14.0
	E02023W-156A-00	E02023W-158A-00	E02023W-151A-00	240	2000	4.8	14.0
	E02033W-156A-00	E02033W-158A-00	E02033W-151A-00	380	2000	3.0	14.0
	E02043W-156A-00	E02043W-158A-00	E02043W-151A-00	480	2000	2.4	14.0

Class I, Group D heaters with thermostat for hazardous locations also available.

Substitute the letter "W" in part number with the letter "E" to specify Class I, Group D heaters.

Industrial Immersion Heaters are also available for coolants and other process heating. Call factory.

HOTSTART immersion heaters are complete with a fixed-setting, built-in thermostat (shown below). All models are also available with an adjustable thermostat (pg. 31). Ideal for heating hydraulic reservoirs on construction equipment and the sumps of large industrial engines.

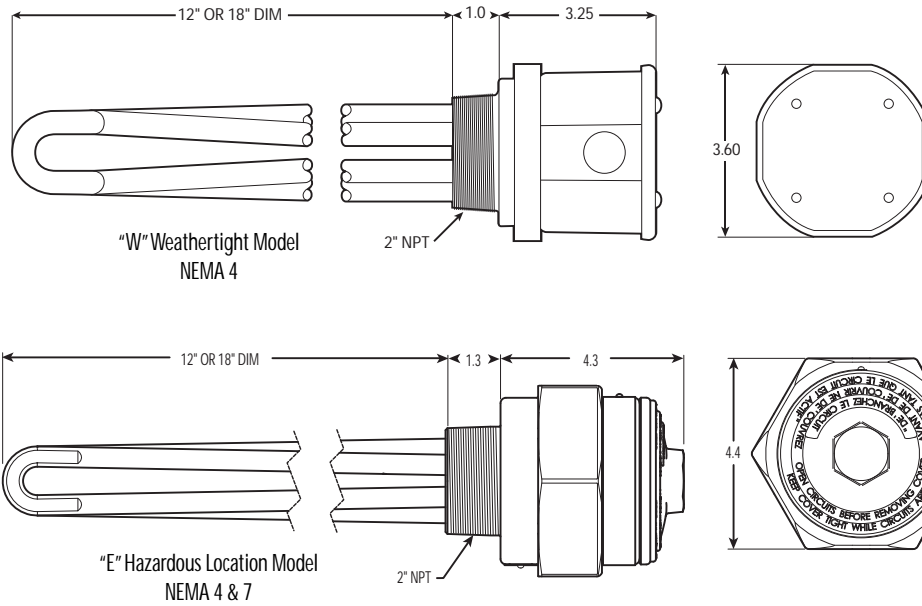

Industrial Immersion Heaters

2" Screw Plug



"W" Weathertight Model
NEMA 4



"E" Hazardous Location Model
NEMA 4 & 7

FIXED THERMOSTAT ASSEMBLY

Thermostat assembly shown in "EP" housing.

ELECTRICAL RATING		
15 Amps	at	120 VAC
10 Amps	at	240 VAC
10 Amps	at	277 VAC

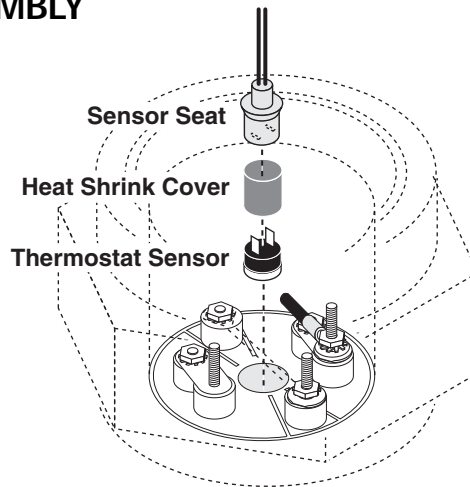

NOTES:

On applications where level of fluid is subject to change, a liquid level switch mounted a minimum of 3 to 4 inches above element is recommended. **Liquid level switch is not included with heater.**

All 380 Volt and 480 Volt heaters must be used in conjunction with contactor and control transformer.

All three phase heaters must be used with a contactor. See pages 37 & 38.

Higher or lower temperature ranges are available. Consult HOTSTART.

TYPICAL WIRING DIAGRAMS

Three phase and single phase above 277 VAC

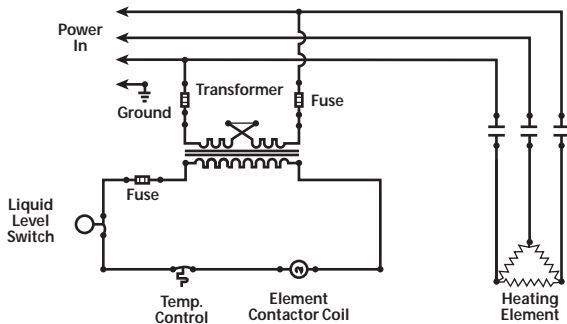

Single phase 277 VAC and below

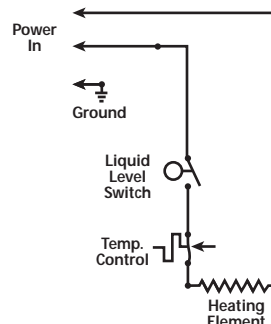

Industrial Immersion Heaters

V-Clamp Threadless Design

*For: Lube Oils,
Hydraulics and
Diesel Fuels*

*With Fixed-Setting,
Built-In Thermostat (Pg. 29)
or Adjustable
Thermostat (Pg. 31)*

*Weather Tight
NEMA 4 Enclosure*

Models for larger capacities than shown are available. Call factory.

Oil Capacity	HIGH LIMIT THERMOSTAT CONTROL SETTING			Volts	Watts	Amps	Watts Sq. In.
	On 60° F / Off 80° F	On 80° F / Off 100° F	On 100° F / Off 120° F				
SINGLE PHASE — WITH A 12" PROBE LENGTH							
30 to 45 Gallons	E01011W-156V-00	E01011W-158V-00	E01011W-151V-00	120	1000	8.3	17.0
	E01081W-156V-00	E01081W-158V-00	E01081W-151V-00	208	1000	4.8	17.0
	E01021W-156V-00	E01021W-158V-00	E01021W-151V-00	240	1000	4.2	17.0
	E01071W-156V-00	E01071W-158V-00	E01071W-151V-00	277	1000	3.6	17.0
45 to 60 Gallons	E01511W-156V-00	E01511W-158V-00	E01511W-151V-00	120	1500	12.5	17.0
	E01581W-156V-00	E01581W-158V-00	E01581W-151V-00	208	1500	7.2	17.0
	E01521W-156V-00	E01521W-158V-00	E01521W-151V-00	240	1500	6.3	17.0
	E01571W-156V-00	E01571W-158V-00	E01571W-151V-00	277	1500	5.4	17.0
THREE PHASE — WITH A 12" PROBE LENGTH							
30 to 45 Gallons	E01083W-106V-00	E01083W-108V-00	E01083W-101V-00	208	1000	2.8	11.0
	E01023W-106V-00	E01023W-108V-00	E01023W-101V-00	240	1000	2.4	11.0
	E01033W-106V-00	E01033W-108V-00	E01033W-101V-00	380	1000	1.5	11.0
45 to 60 Gallons	E01583W-156V-00	E01583W-158V-00	E01583W-151V-00	208	1500	4.2	17.0
	E01523W-156V-00	E01523W-158V-00	E01523W-151V-00	240	1500	3.6	17.0
	E01533W-156V-00	E01533W-158V-00	E01533W-151V-00	380	1500	2.3	17.0
	E01543W-156V-00	E01543W-158V-00	E01543W-151V-00	480	1500	1.8	17.0
SINGLE PHASE — WITH A 18" PROBE LENGTH							
60 to 90 Gallons	E02011W-156V-00	E02011W-158V-00	E02011W-151V-00	120	2000	16.7	14.0
	E02081W-156V-00	E02081W-158V-00	E02081W-151V-00	208	2000	9.6	14.0
	E02021W-156V-00	E02021W-158V-00	E02021W-151V-00	240	2000	8.4	14.0
	E02071W-156V-00	E02071W-158V-00	E02071W-151V-00	277	2000	7.2	14.0
	E02031W-156V-00	E02031W-158V-00	E02031W-151V-00	380	2000	5.3	14.0
	E02041W-156V-00	E02041W-158V-00	E02041W-151V-00	480	2000	4.2	14.0
THREE PHASE — WITH A 18" PROBE LENGTH							
60 to 90 Gallons	E02083W-156V-00	E02083W-158V-00	E02083W-151V-00	208	2000	5.6	14.0
	E02023W-156V-00	E02023W-158V-00	E02023W-151V-00	240	2000	4.8	14.0
	E02033W-156V-00	E02033W-158V-00	E02033W-151V-00	380	2000	3.0	14.0
	E02043W-156V-00	E02043W-158V-00	E02043W-151V-00	480	2000	2.4	14.0

Class I, Group D heaters with thermostat for hazardous locations also available.

Substitute the letter "W" in part number with the letter "E" to specify Class I, Group D heaters.

Industrial Immersion Heaters are also available for coolants and other process heating. Call factory.

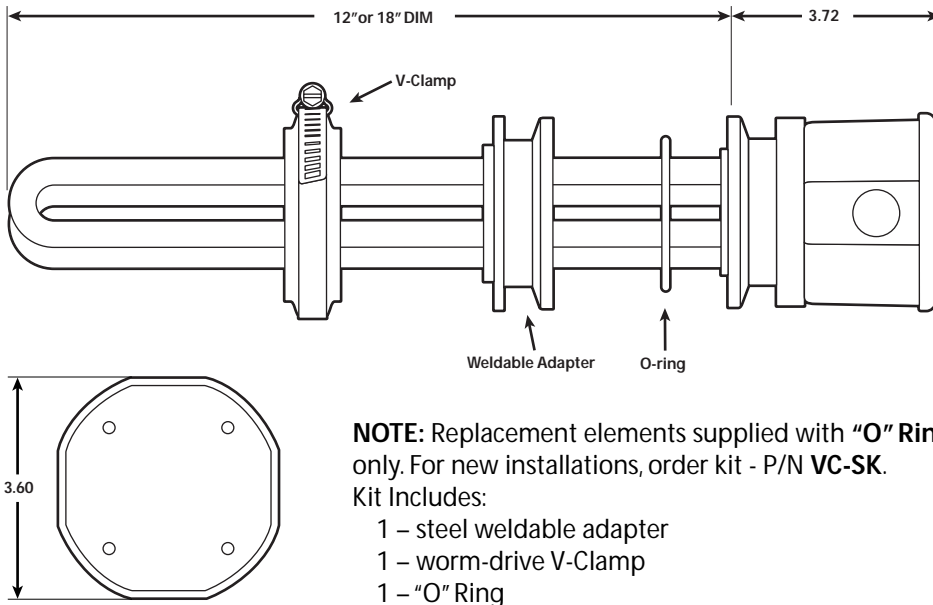

V-Clamp Industrial Immersion Heater

Threadless Design

HOTSTART immersion heaters are complete with a fixed-setting, built-in thermostat (shown on page 29). All models are available with an adjustable thermostat (shown below). Consult factory for model number.

Ideal for heating hydraulic reservoirs on construction equipment and the sumps of large industrial engines.

ADJUSTABLE THERMOSTAT ASSEMBLY

TEMPERATURE RANGE	
OFF	70°F to 210°F
ELECTRICAL RATING	
30 Amps	at 125 VAC
30 Amps	at 240 VAC
30 Amps	at 277 VAC
20 Amps	at 480 VAC
Nominal thermal differential is 8°F	



"W" Weathertight Model
NEMA 4



"E" Hazardous Location Model
NEMA 4 & 7

NOTES:

On applications where level of fluid is subject to change, a liquid level switch mounted a minimum of 3 to 4 inches above element is recommended. **Liquid level switch is not included with heater.**

All 380 Volt and 480 Volt heaters must be used in conjunction with contactor and control transformer.

All three phase heaters must be used with a contactor. See pages 37 & 38.

Higher or lower temperature ranges are available. Consult HOTSTART.

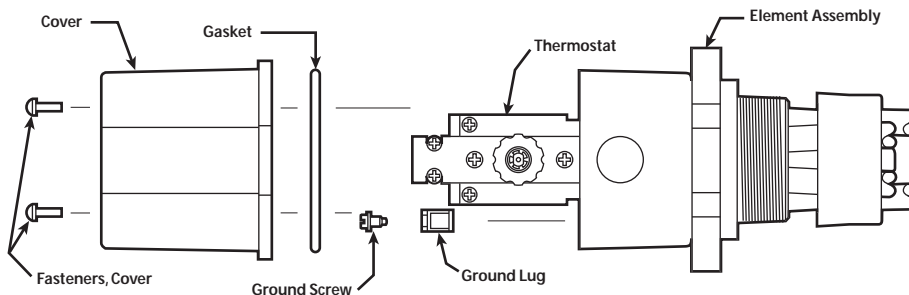

Call HOTSTART for complete model number featuring adjustable thermostat.

DC Oil Heaters

12 and 24 volt

12 VOLT/24 VOLT DC CONTROL BOXES		
25 Amps Maximum	12V 24V	JBMC330DC-12V JBMC330DC-24V



When used with a thermostat control, all DC oil heaters must use a DC relay

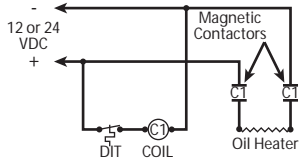

Oil Capacity	Volts	Watts	HOTSTART Model Numbers			Amps	Watts Per Square Inch
			1/2" N.P.T. With a 4" Probe Length	3/4" N.P.T. With a 4 7/8" Probe Length	1" N.P.T. With a 5 3/8" Probe Length		
2 Quarts or Less	12	75	OW207900-012	OW407900-012	—	6.3 3.1	1/2" are all 14.7 WSI 3/4" are all 7.3 WSI
	24	75	OW207900-024	OW407900-024	—		
2 to 6 Quarts	24	125	OW212900-024	—	—	5.2	24.6 WSI
1 to 5 Gallons	12	150	—	OW415900-012	OW615900-012	12.5 6.3	3/4" are all 14.6 WSI 1" are all 10.7 WSI
	24	150	—	OW415900-024	OW615900-024		
5 to 15 Gallons	12	300	—	—	OW630900-012	25.0 12.5	3/4" are all 29.3 WSI 1" are all 21.4 WSI
	24	300	—	OW430900-024	OW630900-024		
15 to 30 Gallons	24	500	—	—	OW650900-024	20.8	35.7 WSI

Please see page 27 for photos and technical drawings of "OW" and "OE" style oil heaters.

12 Volt and 24 Volt DC oil heaters can be powered directly from the battery, but will drain the battery very rapidly unless charged by an alternator or generator.

NOTE: Heater amperage as shown in the table above will determine the life of the battery — (Amps x Hours = Amp hours).

Example: A 12.5 Amp heater will completely drain a 100 Amp-hour battery in 8 hours. $\frac{100 \text{ Amp-hour}}{12.5 \text{ Amp}} = 8 \text{ Hours}$

Temperature Controls



Weathertight

Weathertight models are furnished with a 3 ft. 16/3 HPN power cord. Class I, Group D model is furnished with 18" of lead wire for connection to the power leads in an approved splice box.



Class I, Group D Hazardous Location

Lube oil temperature controls hold lube oil at the desired temperature.

If the heater is energized while the engine is hot or running, Kim Hotstart recommends using thermostats with all lube oil heaters to protect the oil from overheating.

The sensing unit can be changed without draining the sump.



Weathertight Model Number	Class I, Group D Model Number	Temp. Range		Thread Size	Switch Capacity
		On	Off		
DIT68	DIT68EP	60°F	80°F	1/2" N.P.T.	120v - 15 amps 208v - 10 amps 240v - 10 amps 277v - 10 amps 12v DC } Pilot Duty Only 24v DC }
DIT810	DIT810EP	80°F	100°F	1/2" N.P.T.	
DIT1012	DIT1012EP	100°F	120°F	1/2" N.P.T.	
DIT1214	DIT1214EP	120°F	140°F	1/2" N.P.T.	

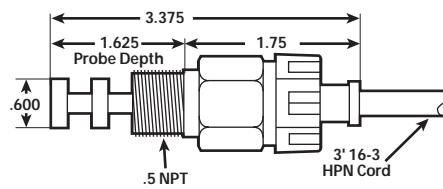

Weathertight Model Dimensions

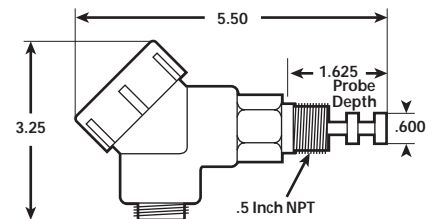

Class 1, Group Model Dimensions

Section 4

Thermostat Controls

Pressure Switch

Magnetic Contactors

Junction Boxes

Complete Control Systems – for manual and automatic start engines



Temperature Controls

Weathertight

NOTE: When using a thermostat above 277 volt or on 3 phase applications, select the proper control box with transformer and contactor as shown on pages 37 or 38.



Fixed Setting

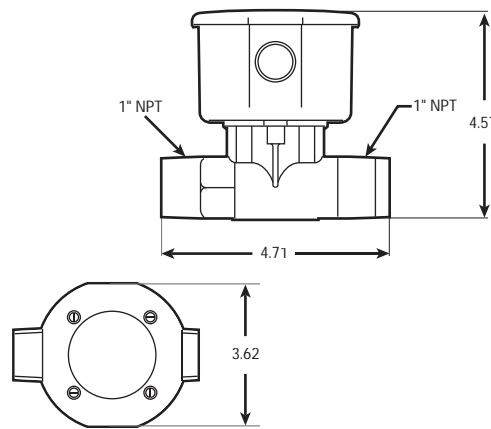

1" NPT x 1" NPT CONDUIT TYPE ENCLOSURE				
Part Number	Temp. Setting		Maximum Capacity Ratings	
	On	Off	120/240Volt	277 Volt
TFTC6-1NPT	60°F	80°F	25 amps	22 amps
TFTC8-1NPT	80°F	100°F	25 amps	22 amps
TFTC10-1NPT	100°F	120°F	25 amps	22 amps
TFTC12-1NPT	120°F	140°F	25 amps	22 amps
TFTC14-1NPT	140°F	160°F	25 amps	22 amps

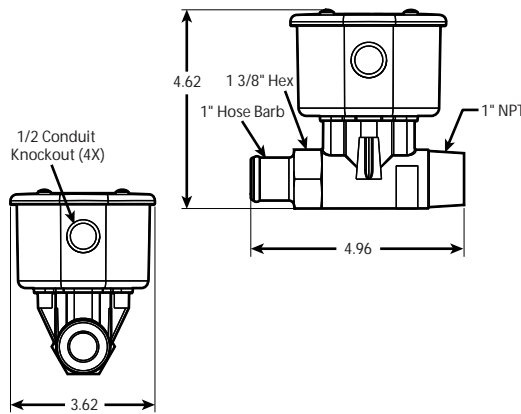

1" NPT x 1" HOSE BARB CONDUIT TYPE ENCLOSURE				
Part Number	Temp. Setting		Maximum Capacity Ratings	
	On	Off	120/240Volt	277 Volt
TFTC6-1HB	60°F	80°F	25 amps	22 amps
TFTC8-1HB	80°F	100°F	25 amps	22 amps
TFTC10-1HB	100°F	120°F	25 amps	22 amps
TFTC12-1HB	120°F	140°F	25 amps	22 amps
TFTC14-1HB	140°F	160°F	25 amps	22 amps

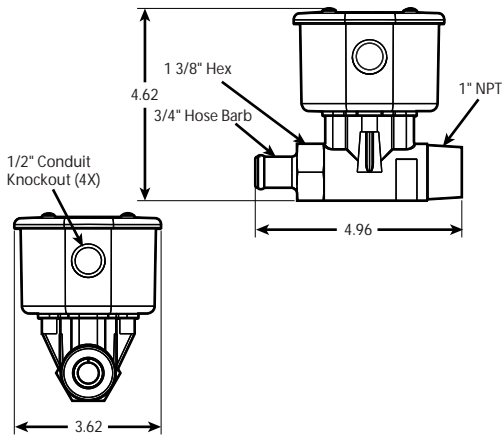

1" NPT x 3/4" HOSE BARB CONDUIT TYPE ENCLOSURE				
Part Number	Temp. Setting		Maximum Capacity Ratings	
	On	Off	120/240Volt	277 Volt
TFTC6-3HB	60°F	80°F	25 amps	22 amps
TFTC8-3HB	80°F	100°F	25 amps	22 amps
TFTC10-3HB	100°F	120°F	25 amps	22 amps
TFTC12-3HB	120°F	140°F	25 amps	22 amps
TFTC14-3HB	140°F	160°F	25 amps	22 amps

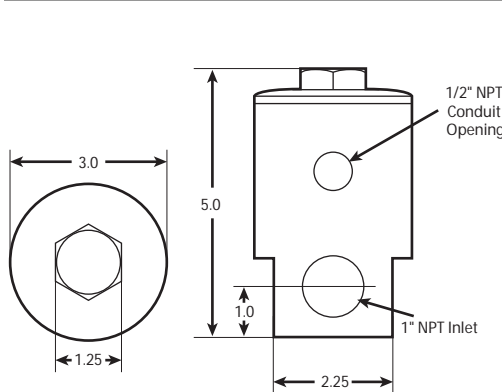

CLASS 1, GROUP D CONDUIT TYPE ENCLOSURE				
Part Number	Temp. Setting		Maximum Capacity Ratings	
	On	Off	120/240Volt	277 Volt
TFT6ER	60°F	80°F	25 amps	22 amps
TFT8ER	80°F	100°F	25 amps	22 amps
TFT10ER	100°F	120°F	25 amps	22 amps
TFT12ER	120°F	140°F	25 amps	22 amps
TFT14ER	140°F	160°F	25 amps	22 amps



Temperature Controls

Weathertight

NOTE: When using a thermostat above 277 volt or on 3 phase applications, select the proper control box with transformer and contactor as shown on pages 37 or 38.

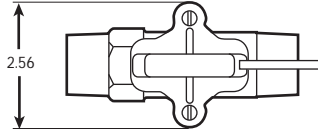
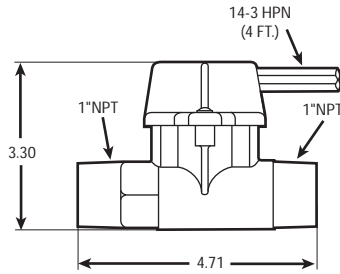

1" NPT x 1" NPT CORD TYPE ENCLOSURE				
Part Number	Temp. Setting		Maximum Capacity Ratings	
	On	Off	120/240 Volt	277 Volt
TFT6-1NPT	60°F	80°F	25 amps	22 amps
TFT8-1NPT	80°F	100°F	25 amps	22 amps
TFT10-1NPT	100°F	120°F	25 amps	22 amps
TFT12-1NPT	120°F	140°F	25 amps	22 amps
TFT14-1NPT	140°F	160°F	25 amps	22 amps

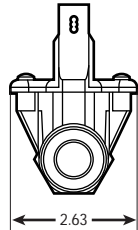
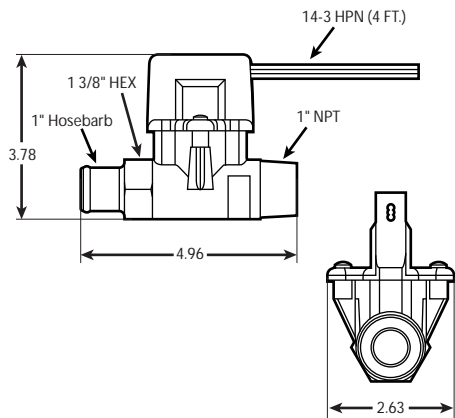

1" NPT x 1" HOSE BARB CORD TYPE ENCLOSURE				
Part Number	Temp. Setting		Maximum Capacity Ratings	
	On	Off	120/240 Volt	277 Volt
TFT6-1HB	60°F	80°F	25 amps	22 amps
TFT8-1HB	80°F	100°F	25 amps	22 amps
TFT10-1HB	100°F	120°F	25 amps	22 amps
TFT12-1HB	120°F	140°F	25 amps	22 amps
TFT14-1HB	140°F	160°F	25 amps	22 amps

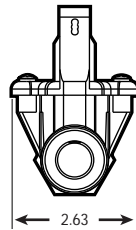
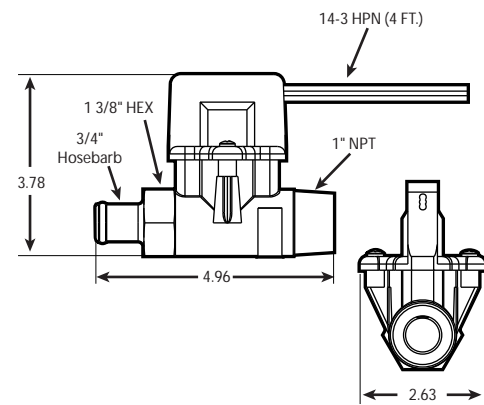

1" NPT x 3/4" HOSE BARB CORD TYPE ENCLOSURE				
Part Number	Temp. Setting		Maximum Capacity Ratings	
	On	Off	120/240 Volt	277 Volt
TFT6-3HB	60°F	80°F	25 amps	22 amps
TFT8-3HB	80°F	100°F	25 amps	22 amps
TFT10-3HB	100°F	120°F	25 amps	22 amps
TFT12-3HB	120°F	140°F	25 amps	22 amps
TFT14-3HB	140°F	160°F	25 amps	22 amps

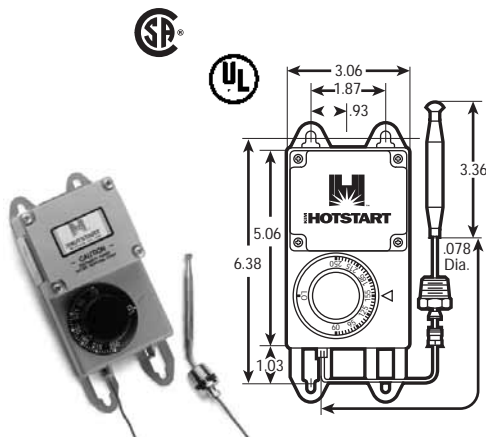

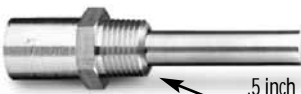
REMOTE-MOUNT ADJUSTABLE With 60" Capillary Probe	
Part Number	Adjustable Range 65°F to 250° (Open or Off Setting) Differential 7°F (Close or On Setting)
AT6525	Maximum Capacity Ratings 120/240 Volt – 25 Amps 277 Volt – 22 Amps
ATW Aluminum Protective Well for AT6525	 .5 inch NPT

Temperature Controls

Adjustable Thermostat

Reduce engine heater cycle time in both warm and cold ambient temperatures.



HOTSTART offers an adjustable thermostat as an option on weathertight engine preheaters and as a stand-alone unit. Control your optimum desired temperature with Kim Hotstart's adjustable thermostat.

- Adjustable from 90°F to 130°F.
- Stock one thermostat to fit all needs.
- 5/8" hose barb or 1" NPT thread connections allow for easy in-line installations on a variety of heating units.
- Weather resistant enclosure.
- Rated up to 480 volts.



Cord Type

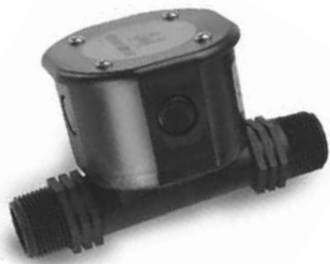
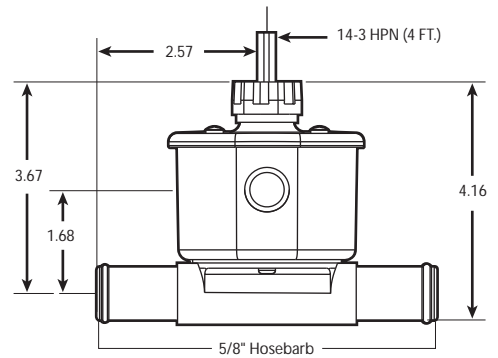

Conduit Type Model Number	Type Plumbing Connections	Cord Type Model Number
TFTCA-1NPT TFTCA-5/8HB	1" NPT X 1" NPT 5/8" HB X 5/8" HB	TFTA-1NPT TFTA-5/8HB

Adjustable Range	Electrical Rating
90°F to 130°F (Open or Off Setting) Differential 20°F (Close or On Setting)	120/240 Volt — 25 Amps 277 Volt — 22Amps 480 Volt — 12.5 Amps

Conduit Type

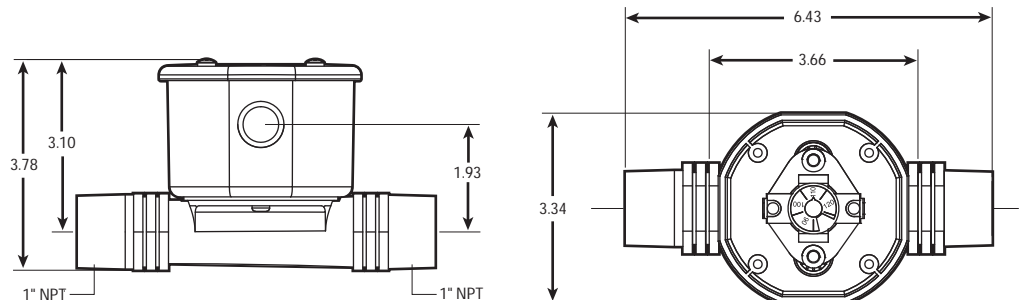

Oil Pressure Switches

For automatic cut-off of heaters when engine starts

Maximum Current Capacity:
 120V/208V/240V/277V — 25 Amps
 380V/480V/575V — 15 Amps
 Two pole single throw.

To prevent overheating of the heating element on standby equipment and automatic start engines, HOTSTART recommends turning the coolant heater off when the engine is running. A pressure switch that senses engine oil pressure is utilized to shut the heater off on increase of oil pressure and to turn the heater on when engine oil pressure drops.

Kim Hotstart Model Number	Enclosure Type
PS252	Dry Locations
PS252R	Dry Locations (Reverse Action)
PS252WT	Wet Locations
PS252EP	Hazardous Locations

PS252



Magnetic Contactors

30 AMPS	Kim Hotstart Model Number	Coil Voltage
	DRY LOCATIONS	
	MC330L MC330	120V 240V
WET LOCATIONS		
	JBW11-000 JBW12-000	120V 240V
HAZARDOUS LOCATIONS		
	JBE11-000 JBE12-000	120V 240V

Inrush Voltamps (VA) 35 VA
 Holding Voltamps (VA) 8 VA

60 AMPS	Kim Hotstart Model Number	Coil Voltage
	DRY LOCATIONS	
	MC360L MC360	120V 240V
WET LOCATIONS		
	JBW11-060 JBW12-060	120V 240V
HAZARDOUS LOCATIONS		
	JBE11-060 JBE12-060	120V 240V

Inrush Voltamps (VA) 92 VA
 Holding Voltamps (VA) 10 VA

MC330



Junction Boxes

Use to simplify wiring on equipment when a variety of heaters and controls are required. All models have ten, 25 Amp terminal blocks.

Part Number	Number of Openings
PDB-000	8*

* Box comes assembled with 4 strain relief connectors. For additional connectors, order part# PDB-1.

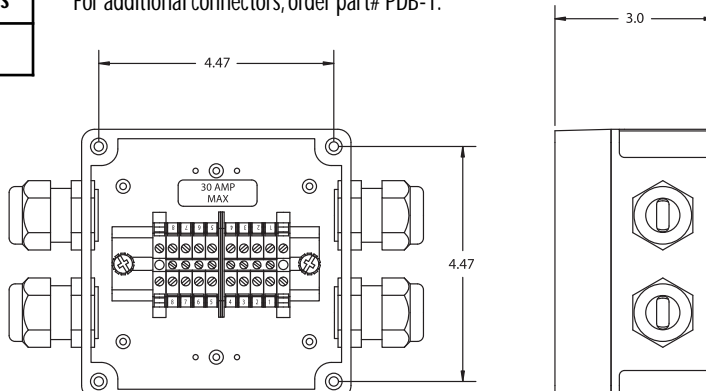

PDB-000



PDB-1



Control Components

Complete Control Systems

For heater protection and power savings HOTSTART recommends de-energizing the heater when engine is running. On automatic start engines this can be accomplished with a control system using an Oil Pressure Switch or a 24 Volt Relay.

Volts	HOTSTART Model Number MANUAL START ENGINES	Amps	HOTSTART Model Number AUTOMATIC START ENGINES	Volts
Single Ø — One Heater and Thermostat Per Engine				
120V 208V 240V 277V	Use thermostat only. See pages 32 through 36.	25 Amps or Less	Use oil pressure switch (PS252) & thermostat. See pages 32-36 and page 37.	120V 208V 240V 277V
Three Ø — One Heater and Thermostat Per Engine				
Single Ø — Two Heaters and Two Thermostats Per Engine				
120V 208V 240V 277V	Use one thermostat with each heater. See pages 32 through 36.	25 Amps Per Heater or Less	Use one oil pressure switch (PS252) & thermostat with each heater. See pages 32 through 36 and page 37.	120V 208V 240V 277V
380V 480V 575V	JBW23-000 JBW24-000 JBW25-000	D	JBW23-100 JBW24-100 JBW25-100	380V 480V 575V
120V 208V 240V 380V 480V 575V	JBW21-000 JBW28-000 JBW22-000 JBW23-000 JBW24-000 JBW25-000	C	JBW21-100 JBW28-100 JBW22-100 JBW23-100 JBW24-100 JBW25-100	120V 208V 240V 380V 480V 575V
Three Ø — Two Heaters and Two Thermostats Per Engine				
208V 240V 380V 480V 575V	JBW28-000 JBW22-000 JBW23-000 JBW24-000 JBW25-000	C	JBW28-100 JBW22-100 JBW23-100 JBW24-100 JBW25-100	208V 240V 380V 480V 575V

All control boxes are available for Class 1 Group D hazardous locations, change prefix "JBW" to "JBE". Consult factory for price and availability.

Box Size Code: A – 6 x 6 x 4, B – 8 x 8 x 4, C – 10 x 8 x 4, D – 12 x 10 x 5

All HOTSTART heaters with thermostats, designed to operate on 3-phase current (at any voltage), require the use of a control system with a 3-pole contactor. All Kim Hotstart heaters with thermostat designed to operate over 480 volt (1 phase or 3 phase) require a control system to reduce the primary voltage to 120 volts for the control circuit. For increased thermostat life, use a control system on all heaters above 277 volts either single or three phase.

These control systems allow for quick electrical installation of all HOTSTART engine preheaters. They are designed as a time and labor saving component. They are especially useful on installations that require two coolant heaters or combinations of a coolant heater and oil heater/hydraulic heater etc.

All control boxes on this and preceding page are NEMA 12 & 13.

All control boxes are available for Class 1 Group D hazardous locations. Change prefix "JBW" to "JBE" and consult factory for price and availability.

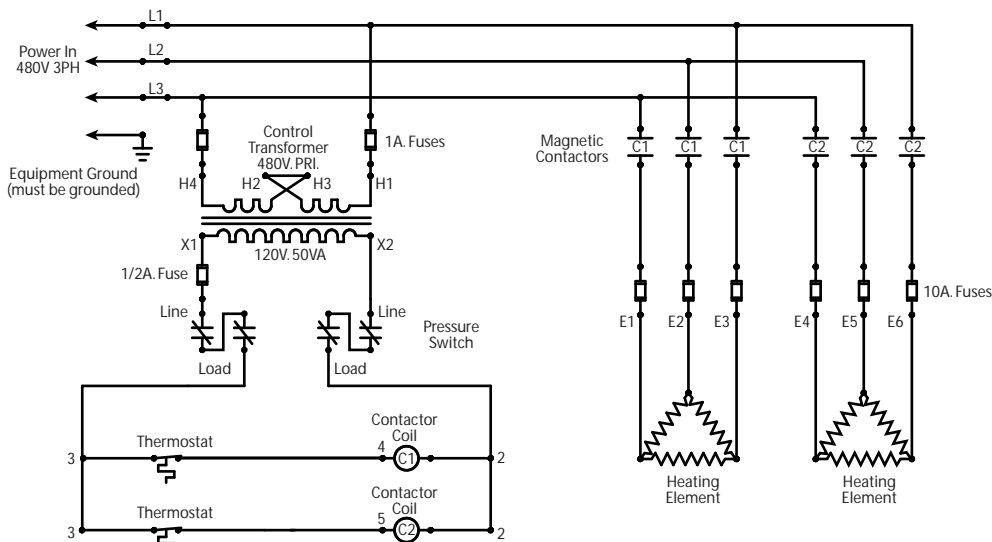

To control two 480 volt heaters at maximum 30 amps on automatic start engines.

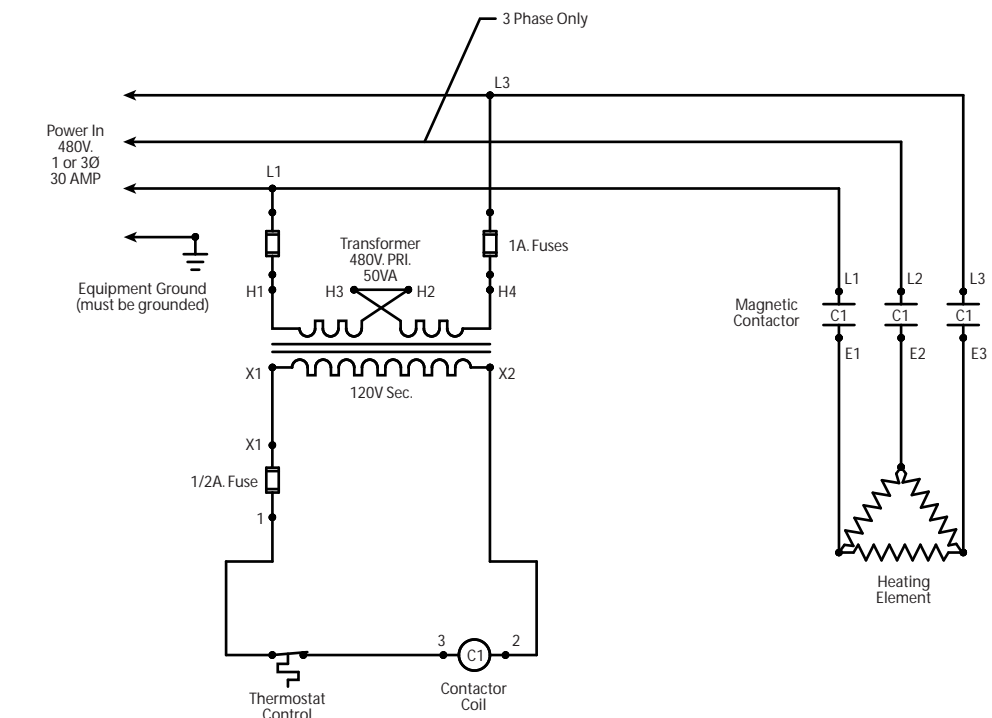

To control one 480 volt heater at maximum 30 amps on manual start engine.

Typical Control Box System Components



Model JBW24-200
With pressure switch
or
Model JBW24-100
With 24 volt relay



Model JBW14-000
No automatic control

Technical Information & Heater Installation Instructions

OPERATING PRINCIPLE

The HOTSTART engine heater operates on the principle of a thermosiphon. As the temperature of the coolant in the heater tank increases, its density decreases causing it to rise through the outlet of the tank to the engine. The coolant leaving the heater tank is replaced with coolant drawn from the engine and the cycle is repeated. A flow-through thermostat is available for the inlet of the engine heater that keeps coolant within the preset temperature range.

CAUTION

Prior to heater installation, check the cooling system. Poor coolant conditions will interfere with proper function of the heater and can also cause element failure. If there is sediment or foreign matter present or the coolant does not meet the engine manufacturer's specifications, the system should be drained, cleaned, flushed and refilled with a 50/50 mixture of low silicate antifreeze, deionized water, and low silicate supplemental coolant additives. Do not exceed a concentration of more than 60% antifreeze, as element failure may result. A cooling system containing anti-leak additives can cause premature element failure.

MOUNTING

Mount the tank heater in a horizontal position with the outlet neck pointed up. The heater can also be mounted vertically with the inlet neck as the low point (see figure 1).

Bolt the heater to the truck frame or skid frame on a generator package with the mounting straps provided. See Figure 2. The heater must be mounted below the lowest level of the engine water jacket to ensure a good gravity flow of coolant to the heater.

CAUTION

DO NOT mount the heater to the engine. Engine vibration can damage the heater and void the warranty.

Connect the heater intake to the lowest accessible point of the water jacket. If a connection point is unavailable in the water jacket area, connect heater intake line to lower radiator hose. This hose should run down to heater intake.

Connect heater outlet to the highest accessible point in the engine's water jacket area at the furthest point from the engine's thermostat. The heater outlet must be connected at a higher point on the engine than the intake. See Figure 3.

CAUTION

DO NOT route outlet hose above engine block connection, or loop or kink hoses. This will cause air locks in the hose and block circulation of the coolant by the heater. See Figure 3.

To eliminate air locks in the heater and hoses, refill the engine with the heater outlet line disconnected at the engine until outlet line is full of coolant. See Figure 4-1. Then connect the outlet line to the engine and finish filling the engine. See Figure 4-2.

Before energizing heater, all air must be bled out of the system by running the engine. If not, air could be trapped in the block causing the heater to fail.

CAUTION

The bi-directional ball check valve located in the inlet of the heater allows a reduced amount of coolant to reverse flow through the heater when the engine is running. This will maintain a full coolant level in the tank at all times to protect the element from overheating. This is a safety device only. Kim Hotstart recommends NOT running the engine with the engine heater energized.

On standby and automatic start engines, heaters should be de-energized when engine starts. This requires an oil pressure switch or other automatic cut-off. These systems are often operated at voltages above the 277 Volt rating of the Kim Hotstart thermostat and are also often 3 Phase. All heaters above 277 Volt should be used in conjunction with a contactor and control transformer. All three phase heaters must be used with a contactor. See pages 37, 38, and 39.

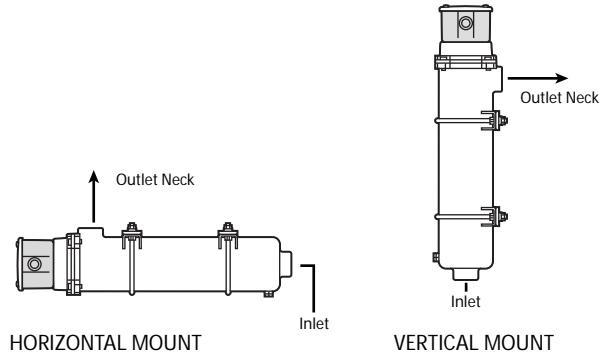

FIGURE 1

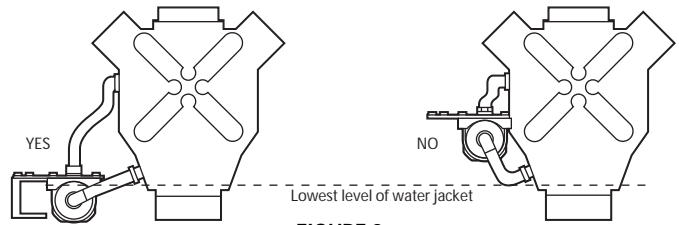

FIGURE 2

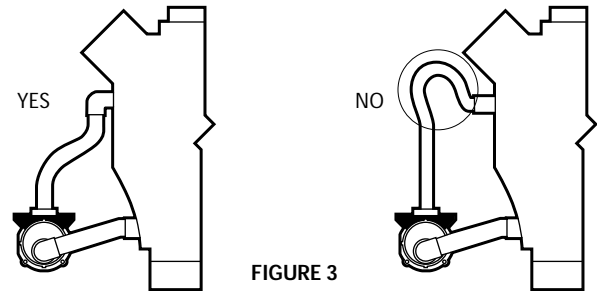

FIGURE 3

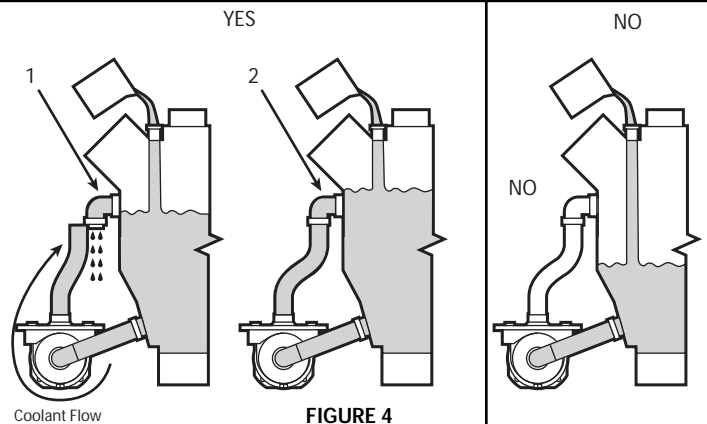

FIGURE 4

Note: It is recommended for "V" engines larger than eight cylinders or over 1000 C.I.D. that 2 heaters of equal wattage be used. One heater installed on each bank of the "V".

Example: To adequately heat a 1000 cubic inch "V" engine for ambient temperature above -20°F use (2) 2000 watt heaters — total 4000 watts.

For the most efficient heating of this size engine and electrical savings, see the forced circulating heating system on pages 16 & 17.

Section 5

Battery Pads

Battery Wraps

Silicone Hot Pads

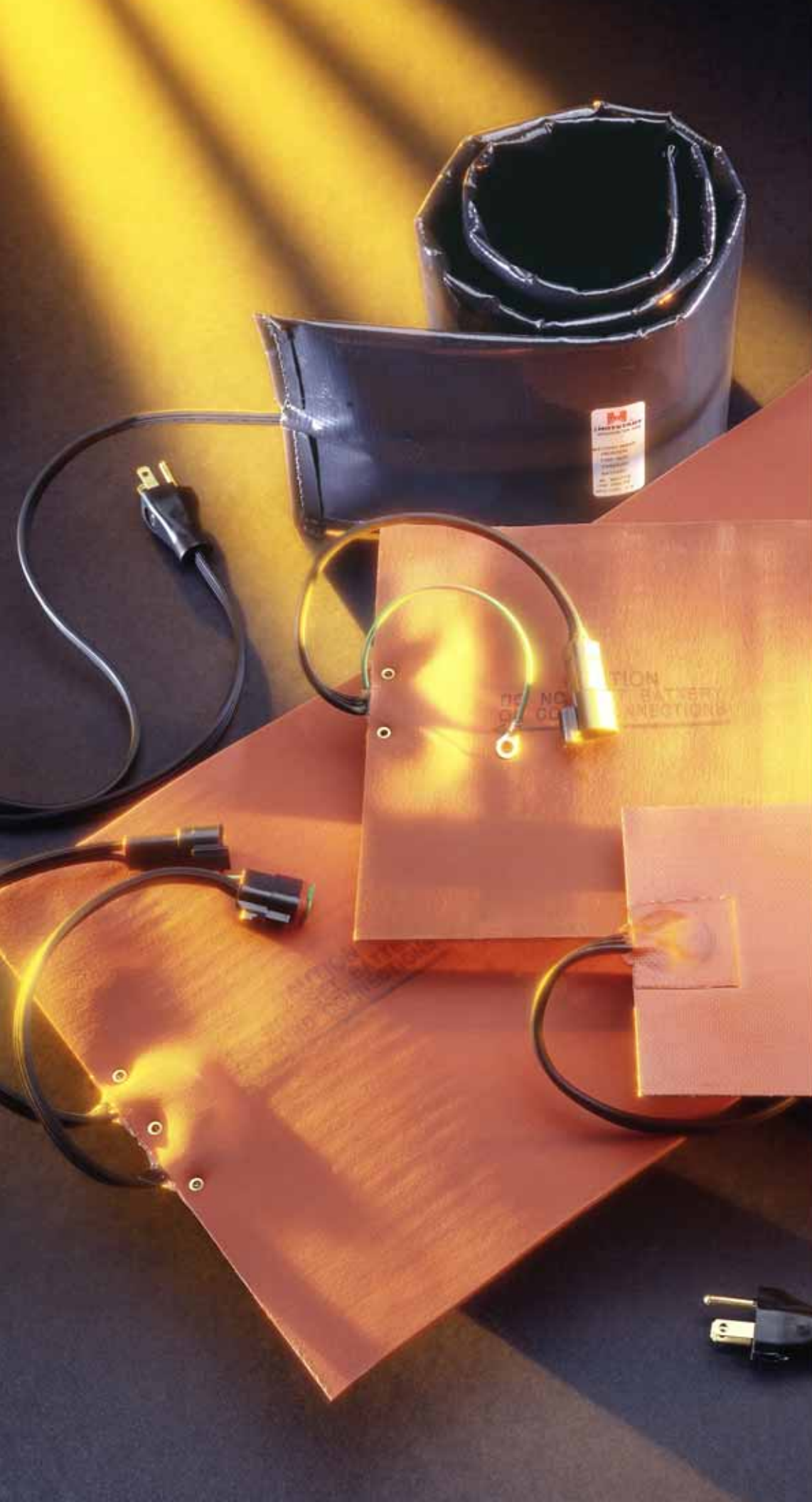

Battery Heating Pads



A fully charged battery has only 40% cranking power at 0° F when compared to 100% cranking power at 80° F.

Battery heater not recommended for nickel cadmium batteries.

When batteries are placed in an insulated battery box, a thermostat is recommended to sense battery box temperature to prevent overheating the battery.

Standard Pad for Single Battery

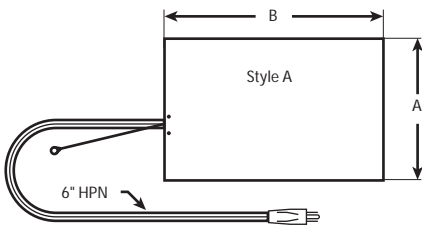

Special Pads for Multiple Batteries

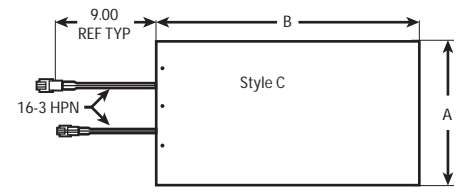
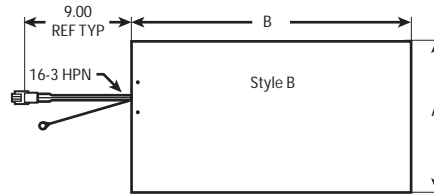

Typical Connection - 2 Batteries on Each Side of Vehicle

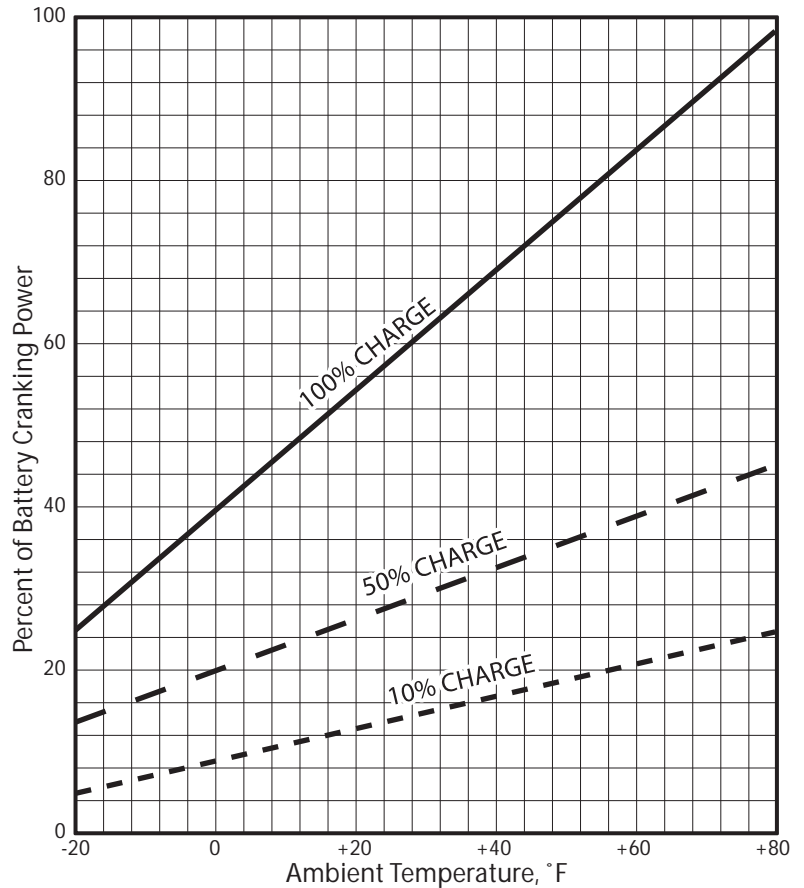
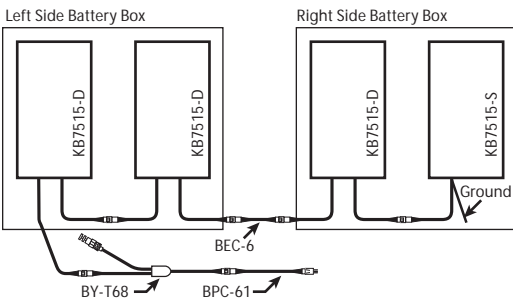

Model Number	Volts	Watts	Amps	Nominal Dimensions		Batt. Size	Style
				A	B		
KB5015	120	50	.42	8 1/4	13	4D	A
KB5015-S	120	50	.42	8 1/4	13	4D	B
KB5015-D	120	50	.42	8 1/4	13	4D	C
KB7515	120	75	.63	10 1/2	19 1/2	8D	A
KB7515-S	120	75	.63	10 1/2	19 1/2	8D	B
KB7515-D	120	75	.63	10 1/2	19 1/2	8D	C
KB7523	240	75	.31	10 1/2	19 1/2	8D	A
KB7523-S	240	75	.31	10 1/2	19 1/2	8D	B
KB7523-D	240	75	.31	10 1/2	19 1/2	8D	C

Accessories For Multiple Battery Heating

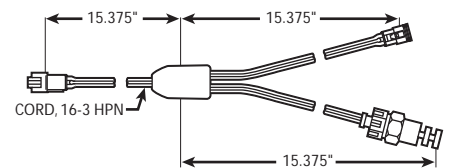
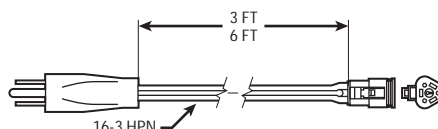
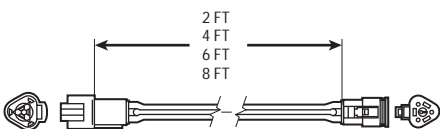

EXTENSION CORDS	
Model	Length
BEC-2	2'
BEC-4	4'
BEC-6	6'
BEC-8	8'

POWER SUPPLY CORDS		
Model	Length	Volts
BPC-31	3'	120
BPC-32	3'	240
BPC-61	6'	120
BPC-62	6'	240

THERMOSTAT & "Y" CORD ASSEMBLY		
Model	Temperature Control	
	On	Off
BY-T68	60°F	80°F

Prolong the life of your battery with HOTSTART thermal battery wraps with or without thermostat.

- Durable, fire-retardant vinyl cover that resists oils and acids.
- All standard battery pads and battery wraps come with 6' grounded cord and plug.
- Fast, easy installation.
- Boosts battery cranking power as much as 75%.

BATTERY THERMAL WRAP — NO THERMOSTAT			
Model Number	Volts	Watts	Length
KBW5015-000	120	50	28"
KBW8015-000	120	80	36"
KBW16015-000	120	160	72"

Thermostatically controlled battery thermal wraps provide optimum heating regardless of ambient temperature.

- At 80°F, the battery will achieve maximum cold cranking amps.
- Battery is constantly maintained at 80°F.
- Provides greater heat rise than plates or pads.
- Thermostat will eliminate battery damage caused by overheating and acid spill.

Thermostat range: 65°F - 80°F

BATTERY THERMAL WRAP — WITH THERMOSTAT			
Model Number	Volts	Watts	Length
KBW5015T-000	120	50	26"
KBW5024T-000	240	50	26"
KBW8015T-000	120	80	44"
KBW8024T-000	240	80	44"
KBW10015T-000	120	100	56"
KBW10024T-000	240	100	56"

Battery Thermal Wrap



Silicone Pad Heaters



Not for use on batteries



Flexible, Versatile and Easy to Install.

HOTSTART adhesive pad heaters are ideal for oil pans, hydraulic reservoirs, engine blocks, hydraulic cylinders and diesel fuel tanks.

- Easy peel and stick application
- Etched foil heating element for optimal heat transfer and long life
- Durable silicone/fiberglass cover resists abrasion
- Assembled with a standard 6 ft. HPN cord and plug (240V without plug)

Model Number	Dimensions	Volts	Watts
AF10015 AF10024	4" x 5"	120 240	100 100
AF15015 AF15024	4" x 5"	120 240	150 150
AF25015 AF25024	5" x 6"	120 240	250 250
AF40015 AF40024	6" x 8"	120 240	400 400

Application Guideline	100 Watt	150 Watt	250 Watt	400 Watt
Engine oil pan	2 to 5 quarts	5 to 8 quarts	2 to 5 gallons	5 to 8 gallons
Diesel Tank	5 to 7 gallons	7 to 10 gallons	10 to 20 gallons	20 to 30 gallons
Hydraulic Tank	1 to 5 gallons	5 to 10 gallons	10 to 20 gallons	20 to 30 gallons
Water Tank	up to 2 gallons	2 to 4 gallons	4 to 7 gallons	7 to 10 gallons

CAUTION: Do not use pads with higher than recommended wattage for specific oil capacities.

Section 6

In-block Heaters

*Heater Installation
Guide*

In-line Heater

*Direct Immersion
Cords*

Thermocords

Flush Mount Kits



















In-Block

Direct Immersion Heaters

Note: In-block heaters are complete with 2-wire w/ground 6 foot HPN cord and plug. For cord replacements or "Y" thermocord energy saver, please reference page 56.



Engine Model	Part Number 120 Volts	Part Number 240 Volts	Watts	Product Image	Application Information	Heat Shield Required	Oil Heater Thread Size*
Allis Chalmers							
670T & I 685T & I 6138LT, T & I 25000 (844 CID)	AC-101 CATV-151	AC-102 CATV-152	1000 1500		Replaces 1" thread-in plug on the oil cooler at rear of the engine on the right side. Note that not all of the engines have this opening.		
Case/IH – Agricultural							
ALL 4 CYL 390 ALL 6 CYL 590	CUB-751FP CUB-101FP CUB-151FP	CUB-752FP CUB-102FP CUB-152FP	750 1000 1500		Inserts in any of the freeze plugs right side of engine		22mm
ALL 6 CYL 830	CUC-151FP	CUC-152FP	1500		Inserts in the freeze plug right rear of the block		22mm
Caterpillar							
C-10 C-12	TF121-000	TF122-000	1250		Replaces the 1" threaded plug in the oil cooler bonnet	YES	1" NPT
C-9 Non ACERT C-15 Non ACERT C-16 Non ACERT	CATV-151	CATV-152	1500		C-9 Only: Mount in rear face of block C-15, C-16: Mount in rear oil cooler bonnet from the back end		1" NPT
C7 ACERT 3126	FP101-001 FP151-001	FP102-001 FP152-001	1000 1500		Replace 44mm frost plug on right hand side of engine just below the turbo charger.	YES	
C7 ACERT rear port	TL101-000	TL102-000			Replace 1-1/16" plug in the rear of the block		
C9 ACERT	CATV-151	CATV-152	1500		Replace 1" NPT plug in the right rear of the engine block		
C11 ACERT C13 ACERT	TF151-008	TF152-008	1500		Replace any of the 1-5/16" plugs in rear of oil cooler on the right hand side of the engine	Check Exhaust Routing	1 5/16" STOR
C15 ACERT w/o breaksaver	TF151-009	TF152-009	1500		Replace 1-3/16" plug in rear of the oil cooler on the right hand side of the engine		
C15 ACERT with breaksaver	TF151-008	TF152-008	1500		Replace 1-5/16" plug in the oil cooler on the right hand side of engine		
C9 2007 ACERT C13 2007 ACERT C15 2007 ACERT	TF151-012	TF152-012	1500		Replace 1-3/16" plug in the rear of the oil cooler on the right hand side of the engine		
1674	CATB-151	CATB-152	1500		Replaces the 1-1/2" thread-in plug on the right side of the engine		
1693 & D343	CATC-151	CATC-152	1500		Replaces water jacket access plate on the left side of the engine		
1693T & 1693TA	CATC-151-S	CATC-152-S	1500		Replaces water jacket access plate on the left side of the engine		
3013 1.5L 3014 2.0L	FP531-003	FP532-003	530		Replaces 40mm core plug on the front, left side of the engine		

* If supplemental oil heating is desired, this column gives the correct thread size in oil pan. See NOTE on page 54.

In-Block

Direct Immersion Heaters

Note: In-block heaters are complete with 2-wire w/ground 6 foot HPN cord and plug. For cord replacements or "Y" thermocord energy saver, please reference page 56.



Engine Model	Part Number 120 Volts	Part Number 240 Volts	Watts	Product Image	Application Information	Heat Shield Required	Oil Heater Thread Size*
Caterpillar — Continued							
3024 2.22L	FP531-003	FP532-003	530		Replaces 40mm core plug on the front, left side of the engine		
3034 2.95L	FP531-001	FP532-001	530		Replaces 50mm core plug located at back of head		
3044 3.3L	PF531-001	PF532-001	530		Mounts in "football shaped" opening on the right of the engine		
3046 5.0L	PF531-000	PF532-000	530		Replaces 35mm core plug located at rear of engine, left side		
3054 3.99L 3054B 4.23L	PER-751FP PER-101FP	PER-752FP PER-102FP	750 1000		Mounts in the 1-1/4" freeze plug opening on the left side of the engine		
3054C	PER-751FP	PER-752FP	750		Mounts in 1-1/4" freeze plug at left rear of engine		
3056 6.0L	PER-151FP	PER-152FP	1500		Mounts in the 1-1/2" freeze plug on the right side of the engine		
3114 3116	FP101-001 FP151-001	FP102-001 FP152-001	1000 1500		Replaces the core plug on the right side of the engine just below the turbocharger	YES	11/16"X12
3176 10.3L through 1995	DD8L-101 CAT-12015 TF151-001	DD8L-102 CAT-12023 TF152-001	1000 1250 1500		Replaces the 3/4" plug on the right side of the engine just below the head.		1" NPT
3176 10.3L 1996 and later	TF121-000	TF122-000	1250		Replaces the 1" threaded plug in the oil cooler bonnet	YES	11/16"X12
3196 12.0L	TF121-000	TF122-000	1250		Replaces 1" threaded plug in oil cooler bonnet	YES	11/16"X12
3204 all 1100 series	CATX-751 CATX-101	CATX-752 CATX-102	750 1000		Replaces the core plug on the right side of the engine just below the turbocharger		22mm
3208 — 2 heaters with a single cord	CATX-2-751-Y	CATX-2-752-Y	1500 total		Use on industrial engines when clear access is available. Replaces any core plug - one on each side of the engine		
3208 Recommended Aftermarket Installation	JD3/4-101IN JD1-101IN JD3/4-151IN JD1-151IN	JD3/4-102IN JD1-102IN JD3/4-152IN JD1-152IN	1000 1000 1500 1500		Replaces any of the 3/4" or 1" plugs on the water transfer casting (right front of the engine). 3/4" use JD3/4 — 1" use JD1		
3304 3306	DD8L-101 CAT-12015 TF151-001	DD8L-102 CAT-12023 TF152-001	1000 1250 1500		Replaces the 3/4" plug on the left side of the engine		
3406C/E 14.6L	AC-101 CATV-151	AC-102 CATV-152	1000 1500		Replaces 1" thread-in plug in the rear of the oil cooler bonnet on the right side of the engine		1" NPT

* If supplemental oil heating is desired, this column gives the correct thread size in oil pan. See NOTE on page 54.

In-Block

Direct Immersion Heaters

Note: In-block heaters are complete with 2-wire w/ground 6 foot HPN cord and plug. For cord replacements or "Y" thermocord energy saver, please reference page 56.



Engine Model	Part Number 120 Volts	Part Number 240 Volts	Watts	Product Image	Application Information	Heat Shield Required	Oil Heater Thread Size*
Caterpillar — Continued							
3406 & 3408 except 1998 ADEM 2	AC-101 CATV-151	AC-102 CATV-152	1000 1500		Replaces 1" thread-in plug in the rear of the oil cooler bonnet on the right side of the engine		1" NPT
3406E 1998 ADEM 2 engines only	TF151-002	TF152-002	1500		Replaces the 1" threaded plug that points downward on the top of the rear of the oil cooler bonnet	YES	1" NPT
3406E ADEM 3 and ADEM 2000 engines	AC-101 CATV-151	AC-102 CATV-152	1000 1500		Replaces 1" thread-in plug in the rear of the oil cooler bonnet on the right side of the engine		1" NPT
3456 15.8L	AC-101 CATV-151	AC-102 CATV-152	1000 1500		Replaces 1" thread-in plug in the rear of the oil cooler bonnet on the right side of the engine		1" NPT
Chevrolet/GMC (Small Truck)							
5.7L V8 (350 CID)	FC601-501	NONE	600		Mounts in the freeze plug in the engine's block No replacement cord available		
6.2L V8 Diesel 6.5L V8 Diesel	FC601-PY2						
Cummins							
6 Cylinder Engines: H, NT, NH, N Family 743 CID, 855 CID, 927 CID, "N14" 1. Cummins engines are often referred to by their horsepower rating "i.e. 350 Cummins" 2. Cummins engines are often referred to as Big Cam, Big Cam2, 3, 4, full flow cooling, etc. All refer to engines of 855 CID Size – listed below							
Group I							
Flat plate design	CUN-151B	CUN-152B	1500		6 bolt flat plate on the right side of the engine. May use either the forward or rear opening depending on clearance.		1" NPT
Flat plate design when the 1/2" NPT opening is used	CUN-151BH	CUN-152BH	1500				1" NPT
Group II							
When an external oil cooler is used..		Note: When a 4 bolt flat plate element design is encountered, remove the next two bolts on the casting, remove the whole casting, and replace the casting and element with either CNT-151B/CNT-152B OR CNT151B90/CNT152B90					
When connection is 1 1/2" rubber hose Engines produced Aug. 1975 thru June 1982	CNT-151B-90	CNT-152B-90	1500		6 bolt, flat plate design with an elbow that will rotate 360 degrees to connect with any hose or casting		1" NPT
Uses an "O" ring for the 1 1/4" water tube connection Engines produced prior to August '75	CNT-151B	CNT-152B	1500		6 bolt, flat plate design with an elbow that will rotate 360 degrees to connect with any hose or casting		1" NPT

* If supplemental oil heating is desired, this column gives the correct thread size in oil pan. See NOTE on page 54.

In-Block

Direct Immersion Heaters

Note: In-block heaters are complete with 2-wire w/ground 6 foot HPN cord and plug. For cord replacements or "Y" thermocord energy saver, please reference page 56.



Engine Model	Part Number 120 Volts	Part Number 240 Volts	Watts	Product Image	Application Information	Heat Shield Required	Oil Heater Thread Size*
Cummins — Continued							
Group III							
For industrial engines with hole pattern reversed	CUN-151BREV	CUN-152BREV	1500		Six bolt flat plate on the right side of the block		1" NPT
Group IV							
1998 and later N14 Industrial	PF151-002	PF152-002	1500		Six bolt flat plate on the right side of the block		1" NPT
Additional Cummins Engine Models							
Cummins A 4 cyl & 6 cyl	CUA-101F	CUA-102F	1000		Inserts in any of the freeze plugs on right side of engine. Element points down.		
ISC/QSC 8.3L ISL/QSL 9.0L	DD8L-101	DD8L-102	1000		3/4" NPT threaded plug in the right rear side of engine		22mm
L10, M11 ISM	CUL-151	CUL-152	1500		Inserts in the forward opening of the heater casting on the right rear of block		1" NPT
OSB 3.9L, 5.9L ISB 5.9	TF751-002	TF752-002	750		3/4" NPT threaded plug in the front of the oil cooler casting		22mm
ISM/QSM 11.0L Flat Plate Design	PF151-003	PF152-003	1500		Right rear. Replaces plate.		1" NPT
QSX, ISX Signature 600	PF151-004	PF152-004	1500		Mounts in the "football shaped" plate on the right side of the block		27mm
4BT 3.9L	CUB-751FP CUB-101FP	CUB-752FP CUB-102FP	750 1000		Inserts in any of the freeze plugs right side of engine	Check Exhaust Routing	22mm
6BT 5.9L	CUB-751FP CUB-101FP CUB-151FP	CUB-752FP CUB-102FP CUB-152FP	750 1000 1500		Inserts in any of the freeze plugs right side of engine	Check Exhaust Routing	22mm
6CT 8.3L	CUC-151FP	CUC-152FP	1500		Inserts in the freeze plug right rear of the block		22mm
Detroit Diesel							
SERIES 10 4 cylinder Phaser engines	PER-751FP PER-101FP	PER-752FP PER-102FP	750 1000		Mounts in the 1-1/4" freeze plug opening on either side of the engine		
SERIES 10 6 cylinder Phaser engines	PER-151FP	PER-152FP	1500		Mounts in the 1-1/2" freeze plug on the right side of the engine		
SERIES 30	DD8L-101	DD8L-102	1000		Mounts in the 3/4" NPT opening in the block		

* If supplemental oil heating is desired, this column gives the correct thread size in oil pan. See NOTE on page 54.

In-Block

Direct Immersion Heaters

Note: In-block heaters are complete with 2-wire w/ground 6 foot HPN cord and plug. For cord replacements or "Y" thermocord energy saver, please reference page 56.



Engine Model	Part Number 120 Volts	Part Number 240 Volts	Watts	Product Image	Application Information	Heat Shield Required	Oil Heater Thread Size*
Detroit Diesel – continued							
SERIES 40 all versions	PER-751FP INTA-121 FR151-001	PER-752FP INTA-122 FR152-001	750 1250 1500		Mounts in the frost plug opening on the left side of the engine		
SERIES 50 SERIES 60	AC-101 CATV-151	AC-102 CATV-152	1000 1500		Mounts in the 1" NPT opening in either water pick up pipe (up to 1991) or in the 1" NPT opening on the oil cooler housing after 1991	yes on 1991 and later	3/4" NPT
SERIES 55	PF151-000	PF152-000	1500		Mounts in the triangle plate on the side of the block		
3-53, 4-53, 3-71, 4-71 with water cooled air compressor	DD-751-S	DD-752-S	750		Mounts in the "football shaped" plate on the block. Check clearance.		
3-53, 4-53, 3-71, 4-71 without water cooled air compressor	DD-751	DD-752	750		Mounts in the "football shaped" plate on the block. Check clearance.		
6-71 with water cooled air compressor	DD-151-S	DD-152-S	1500		Mounts in the "football shaped" plate on the block. Check clearance.		
6-71 without water cooled air compressor	DD-151	DD-152	1500		Mounts in the "football shaped" plate on the block. Check clearance.		
8.2 L V-8 Diesel	DD8L-101	DD8L-102	1000		Threads into the 3/4" NPT opening on the block		
6V-53 with water cooled air compressor	DD6V-751-S	DD6V-752-S	750		Mounts in the "football shaped" plate on the block. Check clearance.		
6V-53 without water cooled air compressor	DD6V-751	DD6V-752	750		Mounts in the "football shaped" plate on the block. Check clearance.		
6V71 & 8V71 Alternate location	AC-101 CATV-151	AC-102 CATV-152	1000 1500		Threads into 1" NPT plug in the front face of the block		
6V-71 & 8V-71 6V-92 & 8V-92 except GMC General models	DDV-151B	DDV-152B	1500		Mounts in the square plate on the block		
6V92 & 8V92 alternate location - threads into oil cooler.	DD8L-101	DD8L-102	1000		Threads into the 3/4" NPT opening in the oil cooler housing. Note - not all engines have this opening		
Deutz							
BF4L913 BF6L913 F3L912 F3L913 F6L913 1011 SERIES oil cooled engines	OLT221515 plus A22M48M (adapter)	n/a	150		Use adapter kit to mount the 22MM heater in the 48MM opening		22MM or 48MM

* If supplemental oil heating is desired, this column gives the correct thread size in oil pan. See NOTE on page 54.

In-Block Direct Immersion Heaters

Note: In-block heaters are complete with 2-wire w/ground 6 foot HPN cord and plug. For cord replacements or "Y" thermocord energy saver, please reference page 56.



Engine Model	Part Number 120 Volts	Part Number 240 Volts	Watts	Product Image	Application Information	Heat Shield Required	Oil Heater Thread Size*
Deutz – continued							
1012 — 4 & 6 cyl 1013 — 4 cyl	PF751-000	PF752-000	750		Mounts in the "football shaped" plate opening on the oil cooler casting		
1013 6 cyl	PF121-001	PF122-001	1250		Mounts in the "football shaped" plate opening on the oil cooler casting		
1015 6 & 8 cyl	TL151-004	TL152-004	1500		Mounts in 30MM plug in water elbow on front of the engine		
2012 — 4 & 6 cyl	PF751-002	PF752-002	750		Mounts in the "football shaped" plate opening on the oil cooler casting		
Ford							
6.9L & 7.3L V-8 diesels through 1993	FC101-PY1	None	1000		Mounts in a freeze plug on the engine's block. No replacement cord available.		
7.3L V-8 diesels from 1994 on	TF751-002 DD8L-101	TF752-002 DD8L-102	750 1000		Mounts in the 3/4" NPT plug in the engine's block		
Hino							
3.8L, 5.8L, 6.0L, 6.4L, 6.7L, W04C-T, W06E, H06C-T, H07C-B	DD8L-101	DD8L-102	1000		Threads into 3/4" NPT opening in the block	YES	
Isuzu							
4BD1 6HE1 6BD1 6SA1 6BG1	TF401-501	NONE	400		Replaces 1" NPT plug in left rear of engine		
Iveco							
NEF 4cyl NEF 6 cyl	PF751-001	PF752-001	750		Mount in either front or rear opening on right side of engine block		
John Deere							
With 3/4" plug in the back of the block	JD3/4-101IN JD3/4-151IN	JD3/4-102IN JD3/4-152IN	1000 1500		3/4" NPT opening in the rear face of the block	check Exhaust routing	
With 1" plug in the back of the block	JD1-101IN JD1-151IN	JD1-102IN JD1-152IN	1000 1500		1" NPT opening in the rear face of the block		
With 1 5/8" opening on the side of the water jacket	JDS-101	JDS-102	1000		1-5/8" threaded opening on the side of the block in the water distribution channel		

* If supplemental oil heating is desired, this column gives the correct thread size in oil pan. See NOTE on page 54.

In-Block

Direct Immersion Heaters

Note: In-block heaters are complete with 2-wire w/ground 6 foot HPN cord and plug. For cord replacements or "Y" thermocord energy saver, please reference page 56.



Engine Model	Part Number 120 Volts	Part Number 240 Volts	Watts	Product Image	Application Information	Heat Shield Required	Oil Heater Thread Size*
John Deere – continued							
6105 (10.5L) 6125 (12.5L)	AC-101 CATV-151	AC-102 CATV-152	1000 1500		1" NPT opening in the oil cooler casting		
Komatsu							
L10 (10L) M11(11L)	CUL-151	CUL-152	1500		Inserts in the forward opening of the heater casting on the right rear of the block		
SA6D125	MA-151	MA-152	1500		Threads into the freeze plug opening in the block		
Kubota							
M, B, L Series D905 V1205 D1005 V1305 D1105 V1505 D3000B V4000B D3200B V4300B DH905 VH1205 DH1005 VH1305	TF401-501	N/A	400		Replaces 1" NPT plug in left front of engine		
Mack							
Mid liner E3 MS200 & MS250	MAM-101	MAM-102	1000		Mounts in rear face of block		
Mid liner E5 MS300	MAM-151	MAM-152	1500		Mounts in the oil cooler bonnet		
E6 engines "smooth bore" from 1981 on	MASB-151	MASB-152	1500		Mounts in the freeze plug opening. Smooth opening design.		
E6 engines threaded freeze plug opening not produced after '81 END 465, 711, EN438, 504, 707, 673, 675, 676 (1957 through 1981)	MA-151	MA-152	1500		Mounts in any threaded freeze plug opening		
E7 Engines Except E-Tech water pump mount	PF151-001	PF152-001	1500		Mounts in the plate in either the front or rear face of the block in the water jacket passage. For 2002 engine – mounts in rear face of block.		
E9, ENDT865, 866 and 1000 series V8 engines Use two heaters	DD8L-101	DD8L-102	2000 total		Threads into the 3/4" NPT opening on each side of the block		

* If supplemental oil heating is desired, this column gives the correct thread size in oil pan. See NOTE on page 54.

In-Block

Direct Immersion Heaters

Note: In-block heaters are complete with 2-wire w/ground 6 foot HPN cord and plug. For cord replacements or "Y" thermocord energy saver, please reference page 56.















Engine Model	Part Number 120 Volts	Part Number 240 Volts	Watts	Product Image	Application Information	Heat Shield Required	Oil Heater Thread Size*
MAN							
D2840 D2842 D2848	PF121-003	PF122-003	1250		Replace "football shaped" plate in lower water pipe on right side of engine		
D2866 D2876	PF151-006	PF152-006	1500		Replace 3 bolt plate on left side of engine. May require adapter if 3 bolt opening is not available on engine. Consult customer service.		
Mercedes Benz							
MBE904 MBE906	PF101-001	PF102-001	1000		Replace frost plug in rear of engine on right side	YES	
Massey Ferguson							
3 cylinder 4 cylinder 6 cylinder	PER-751FP PER-101FP	PER-752FP PER-102FP	750 1000		Mounts in any of the 1-1/4" freeze plug openings in the engine		
Navistar/International							
V800 (796 CID)	AC-101 CATV-151	AC-102 CATV-152	1000 1500		Threads into a 1" NPT opening in the oil cooler bonnet		
INLINE 6 CYLINDER — all series — 312, 360, 414, 436, 466 & 530	PER-751FP INTA-121 FR151-001	PER-752FP INTA-122 FR152-001	750 1250 1500		Mounts in the frost plug on the left side of the engine. Fits all series of these engines.		
6.9L & 7.3L V8 diesels through 1993	FC101-PY1 or FC601-501	None	1000 600		No replacement cord available. Mounts in a freeze plug above starter		
7.3L & T444 all series	DD8L-101	DD8L-102	1000		3/4" NPT threaded opening in the block		
9.0L — V8 diesel	INT9-101F	INT9-102F	1000		Mounts in a freeze plug		
Oliver							
ALL EXCEPT 1265, 1365 & 1900	TF751-002 DD8L-101	TF752-002 DD8L-102	750 1000		Threads into a 3/4" NPT opening in the block		
Onan — See Cummins "A" Series							
Perkins							
3.152 4.236 6.354	PER-751FP PER-101FP	PER-752FP PER-102FP	750 1000		Mounts in the 1-1/4" freeze plug opening on the right side of the engine		
103.15 104.22 404.22	FP531-003	FP532-003	530		Mounts in left front freeze plug		

* If supplemental oil heating is desired, this column gives the correct thread size in oil pan. See NOTE on page 54.

In-Block Direct Immersion Heaters

Note: In-block heaters are complete with 2-wire w/ground 6 foot HPN cord and plug. For cord replacements or "Y" thermocord energy saver, please reference page 56.



Engine Model	Part Number 120 Volts	Part Number 240 Volts	Watts	Product Image	Application Information	Heat Shield Required	Oil Heater Thread Size*
Perkins – continued							
700 Series 704.30	FP531-001	FP532-001	530		Mounts in freeze plug in rear of head		
800 Series	PF531-001	PF532-001	530		Mounts in football shaped plate on the left front of the block		
1004 (right side)	FR751-002 FR101-000 PER-151FP	FR752-002 FR102-000 PER-152FP	750 1000 1500		Mounts in the 1-1/2" freeze plug opening on the right side of the engine		
1004 (left side)	PER-751FP PER-101FP	PER-752FP PER-102FP	750 1000		Mounts in the 1-1/4" freeze plug opening on the left side of the engine		
1006 (6 Cyl) A & B	PER-151FP	PER-152FP	1500		Mounts in the 1-1/2" freeze plug on the right side of the engine		
1103C	FR531-000	FR532-000	530		Replaces 1-1/4" freeze plug on right rear of engine. Element should point towards 10 o'clock position.		
1104 (4 Cyl) C	PER-751FP PER-101FP	PER-752FP PER-102FP	750 1000		Mounts in 1-1/4" freeze plug opening on right rear of engine with element straight up in 12 o'clock position		
Volvo							
D9	PF151-007	PF152-007	1500		Mounts in the "football shaped" plate on the front, right side of the engine		
D12C Prior to Serial # 250502	PF151-005	PF152-005	1500		Mounts below turbo charger on right center of engine	YES	
D12C After Serial # 250502	PF121-002	PF122-002	1250			YES	
TD60, TD61, TD70, TD71, TD100, TD101, VE10, TD120, TD121	VT6-101	VT6-102	1000		Mounts into threaded opening (44mm) in the front of the engine		
Yanmar							
3T72HLE 4TN82E D4T YYDXL4.41	TF401-501	N/A	400		1" NPT No replacement cord available		

NOTE: The only replacement parts for the direct immersion heaters is the power cord. Please see the power cord section on page 56 for the proper replacement cord set.

For thermostat control of in-block direct immersion heaters, see page 56. The energy saver Thermocord is available in various temperature ranges.

Supplemental heat for engines using in-block heaters can be achieved by the installation of oil pan heaters in the lube-oil. Reference pages 26 and 27 of this catalog or consult factory.

* If supplemental oil heating is desired, this column gives the correct thread size in oil pan. See NOTE on page 54.

Heater Installation

Instructions for:
In-block direct immersion heaters

Please refer to specific instructions that accompany heater.

THREADED PLUG TYPE HEATERS



- A. Drain the cooling system.
- B. Remove the recommended plug. (See instructions with heater)
- C. Apply teflon tape to pipe threads or grease to O ring.
- D. Thread heater into engine.

Please follow these steps to ensure proper operation of your Kim Hotstart in-block heater.

1. Align cord with pins on the heater and press the cord into the heater. Place clamp around cord & heater. **DO NOT PLUG IN HEATER YET!**
2. Route the cord, keeping away from hot or moving surfaces.
3. Re-fill the cooling system. Run engine until engine thermostat opens and continue running for another 20 minutes to eliminate air.
4. Stop engine and let cool. Check for leaks. Check coolant level.
5. Plug heater into power supply and test for proper operation. Block should feel warm near heater.

PLATE TYPE HEATERS



- A. Drain the cooling system.
- B. Remove the recommended plate. (See instructions with heater)
- C. Clean the gasket area.
- D. Apply gasket sealant to plate and engine surfaces.
- E. Insert heater into engine. Tighten bolts.

Please follow these steps to ensure proper operation of your Kim Hotstart in-block heater.

1. Align cord with pins on the heater and press the cord into the heater. Place clamp around cord & heater. **DO NOT PLUG IN HEATER YET!**
2. Route the cord, keeping away from hot or moving surfaces.
3. Re-fill the cooling system. Run engine until engine thermostat opens and continue running for another 20 minutes to eliminate air.
4. Stop engine and let cool. Check for leaks. Check coolant level.
5. Plug heater into power supply and test for proper operation. Block should feel warm near heater.

FREEZE (CORE) PLUG TYPE HEATERS







- A. Drain the cooling system.
- B. Remove the recommended core plug. (See instructions with heater)
- C. Clean, smooth and dry core plug opening.
- D. If retaining ring style, apply a light coat of grease to the O ring and core plug opening. If press-in style, apply a light coat of high-temperature, high-strength retaining compound (Loctite 640 recommended).
- E. Insert heater into engine and position properly. Push the heater into the engine by hand, then tap in using a suitable tool until flange is even with engine block.

Please follow these steps to ensure proper operation of your Kim Hotstart in-block heater.

1. Align cord with pins on the heater and press the cord into the heater. Place clamp around cord & heater. **DO NOT PLUG IN HEATER YET!**
2. Route the cord, keeping away from hot or moving surfaces.
3. Re-fill the cooling system. Run engine until engine thermostat opens and continue running for another 20 minutes to eliminate air.
4. Stop engine and let cool. Check for leaks. Check coolant level.
5. Plug heater into power supply and test for proper operation. Block should feel warm near heater.

Replacement Cords & Thermocords

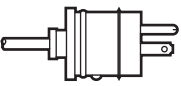
Heat Shield	
Model No.	
HS1	
Use when exhaust manifold or turbo come close to heater termination.	

For use with In-Block Direct Immersion heaters				
Cord Length	Plug Style	120 Volt	240 Volt	STYLE 1
6'	1	IM6-1IN	IM6-2IN	  15 amp 120 Volts
11'	1	IM11-1IN	IM11-2IN	
16'	1	IM16-1IN	IM16-2IN	
Fits most competitor's applications.				
Cord Length	Plug Style	120 Volt	240 Volt	STYLE 2
6'	2	11PR72T	21PR72T	  15 amp 120 Volts Fits into flush mount housing
11'	2	11PR132T	21PR132T	
16'	2	11PR192T	21PR192T	

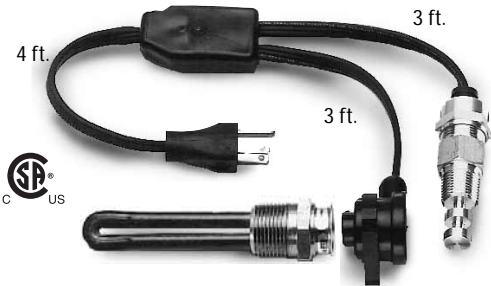

NOTE: When ordering in-block heater **and** thermocord, place suffix **-WOC** (which stands for **without cord**) after the heater model number to save cost as the standard 6 foot heater cord is replaced by the thermocord harness.

Thermocord for In-Block Direct Immersion heaters				ENERGY SAVER
Part No.	Volts	Thread Size	Temp Range	
A-2822-0B	120	1/2"	100-120	 4 ft. 3 ft. 3 ft.
A-2822-0C	120	1/2"	120-140	
A-2822-0H	240	1/2"	100-120	
A-2822-0I	240	1/2"	120-140	
A-2822-0M	120	1/2"	80-100	
A-2822-0P	240	1/2"	80-100	



Heater shown for illustration purposes only.

Flush Mount Kits & Accessories

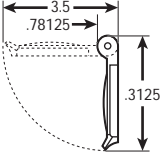
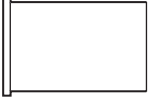
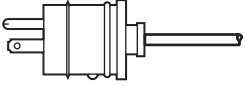
Flush mount kits for In-Block Direct Immersion heaters					
Model Number 120 Volt	Model Number 240 Volt	Cord Length	Plug Style	Kits include: 11PR- style cord (shown on page 56), recessed male receptacle and hinged flip cover	
IM6-1IN-FM	IM6-2IN-FM	6'	2		
IM11-1IN-FM	IM11-2IN-FM	11'	2		
IM16-1IN-FM	IM16-2IN-FM	16'	2		



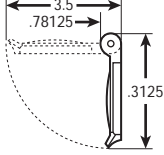

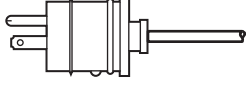
Flush mount kits for tank heaters					
Model Number	Volts	Amps	For Heater with Wattage of:	Kits include: Recessed male receptacle with 6' cord (no female connectors), hinged flip cover and female connector	
FM15120	120	15	500 to 1800		
FM15240	240	15	500 to 3000		
FM20120	120	20	2000 to 2250		

Other Accessories

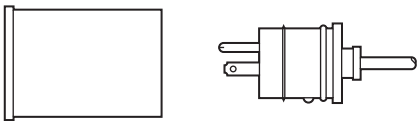
Recessed Male Receptacle – with 6 ft. cord (no female connectors)			
Model Number	Volts	Amps	
RM5-15	120	15	
RM6-15	240	15	
RM5-20 RM6-20	120 240	20 20	

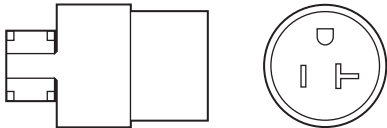
Female Connector Only - for extension cords			
Model Number	Volts	Amps	
FM1G20A	120	15/20	
FM2G20A	240	15/20	

Hinged Cover Only		
Model Number	Description	
*FC-KH FC-KH-C	Black/Kim Logo Chrome/Kim Logo	

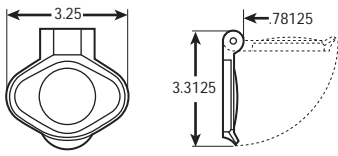
*Note: Standard with kit

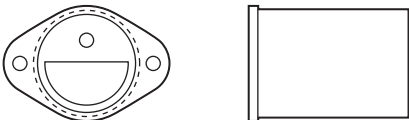
Plug Housing		
Model Number		
A-2223-PH		

Specifying an Engine Pre-Heater

1. Determine the best type of heater to be used for the application.
 - Direct Immersion or Tank Type?
 - Weathertight unit for all indoor or outdoor applications (hospital, communications building, shopping mall, pump station, off-road equipment).
 - Explosion Proof unit for Hazardous Locations (off-shore platform, oil rig, gas compression station).
2. Determine engine size.
 - Cubic inch or litre displacement.
3. Determine wattage required by using this general formula:
 - 3 watts x cubic inch displacement = watts required.
 Example: Engine is 855 C.I.D. — 855 x 3 = 2565. Requirement is 2500 watt heater.
 - This formula is a very good rule of thumb to use down to 0°F ambient temperature. This formula will generally hold engine temperature at approximately 100°F above ambient.
 - Very large engines may require a forced circulation system (see pages 16, 17 and 59).
4. Now that you have the required wattage, you need to determine:
 - Voltage available that will power the heater (120, 208, 277, 240, 380, 480).
 - Is the power source Single Phase or Three Phase?
5. For thermostat selection, determine the desired engine temperature to be maintained.
 - 100°F to 120°F applies 95% of the time. However, specifications vary with respect to the user and a higher or lower range may be required.

You now have the specifications needed to select the required engine pre-heater from the many products listed in this catalog. For other technical information and installation tips, see pages 40 and 55. If you have other questions or need additional assistance, please contact our customer service department.

Conversion Factors
Litres x 1.0567 = Quarts
Quarts x 0.94635 = Litres
Litres x 0.26417 = Gallons
Gallons x 3.7854 = Litres

Cubic Inches - Litres Conversion Chart

Cubic Inches	Litres	Cubic Inches	Litres	Cubic Inches	Litres
150	2.46	1600	26.22	3050	49.98
200	3.28	1650	27.04	3100	50.80
250	4.10	1700	27.86	3150	51.62
300	4.92	1750	28.68	3200	52.44
350	5.74	1800	29.50	3250	53.26
400	6.55	1850	30.32	3300	54.08
450	7.37	1900	31.13	3350	54.90
500	8.19	1950	31.95	3400	55.71
550	9.01	2000	32.77	3450	56.53
600	9.83	2050	33.59	3500	57.35
650	10.65	2100	34.41	3550	58.17
700	11.47	2150	35.23	3600	58.99
750	12.29	2200	36.05	3650	59.81
800	13.11	2250	36.87	3700	60.63
850	13.93	2300	37.69	3750	61.45
900	14.75	2350	38.51	3800	62.27
950	15.57	2400	39.33	3850	63.09
1000	16.39	2450	40.15	3900	63.91
1050	17.21	2500	40.97	3950	64.73
1100	18.03	2550	41.79	4000	65.55
1150	18.84	2600	42.61	4050	66.37
1200	19.66	2650	43.42	4100	67.19
1250	20.48	2700	44.24	4150	68.00
1300	21.30	2750	45.06	4200	68.82
1350	22.12	2800	45.88	4250	69.64
1400	22.94	2850	46.70	4300	70.46
1450	23.76	2900	47.52	4350	71.28
1500	24.58	2950	48.34	4400	72.10
1550	25.40	3000	49.16	4450	72.92

Cubic Inches x 0.01639 = Liters
Liters x 61.024 = Cubic Inches

Conversion Chart
Fahrenheit - Celsius

-40° F	-40° C
-30° F	-34° C
-20° F	-29° C
-10° F	-23° C
0° F	-18° C
10° F	-12° C
20° F	-7° C
30° F	-1° C
40° F	4.5° C
50° F	10.0° C
60° F	15.5° C
70° F	21.0° C
80° F	26.5° C
90° F	32.0° C
100° F	37.5° C
110° F	43.5° C
120° F	49.0° C
130° F	54.5° C
140° F	60.0° C
150° F	65.5° C
160° F	71.0° C
170° F	76.5° C
180° F	82.0° C
190° F	88.0° C
200° F	93.5° C
210° F	99.0° C

F = C x 9/5 + 32
C = (F - 32) x 5/9

HOTSTART offers complete circulating heating systems for any large industrial engine. These systems are engineered and designed specifically for installation on a large generator, compressor package, marine engine, or locomotive. Most systems are mounted on a steel plate with a pre-wired junction box, pump and motor components, a flow detection device and in-line high-limit thermostats. Plus, most systems have fused 120 volt control voltage, regardless of applied voltage.

Several systems are available for lube oil heating, coolant heating, diesel fuel heating or combinations of any aforementioned fluid. Systems are adaptable to function in wet/damp locations or hazardous environments. Complete with all necessary components and controls, these automated systems are available in various wattage, voltage and phase combinations to accommodate most large industrial preheating needs.

For additional information regarding HOTSTART's circulating heating systems, please contact HOTSTART and have all your questions answered by one of our engine heating product specialists.



CL Model
Coolant only, watertight circulating heating system



COLER Model
Class I Group D combination circulating heating system

Large capacity systems heat and circulate coolant or lube oil to efficiently maintain an engine's optimum temperature during shut-down and layover periods.



COR Model for locomotive engines
coolant/lube oil combination heating system

Circulating-type combination heating systems combine the benefits of coolant heating and oil heating into one pre-wired, pre-assembled dual heating system.

OER Model
Oil only, Class I Group D circulating heating system



Lloyds & ABS Approved

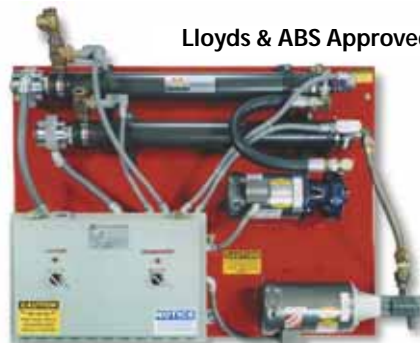

COL Model
Watertight with NEMA 12 enclosures combination circulating heating system

Industrial Circulating Systems - Large engine applications

All HOTSTART circulating heating systems come pre-wired and pre-assembled for easy installation, operation and maintenance.

Customer Services



To better serve you, HOTSTART provides a customer service department to answer all your engine heating concerns, any questions regarding HOTSTART products or to take your sales order.

Customer Support Department:
(509) 536-8660

Sales orders and requests for quotes can also be faxed in over our toll-free FAX line.

Toll-free FAX line: (800) 224-5550

Warranty Information

The warranty below has been drafted to comply with the Federal Law applicable to products manufactured after December 31, 1976. This warranty gives you specific legal rights, and you may also have other rights which vary from state to state.

HOTSTART products are warranted against defects in workmanship and materials. No other express warranty, written or oral, applies. No person is authorized to give any other warranty or assume any liability except by written statement from an officer of HOTSTART Inc.

The warranty extends for twelve months from date of shipment from factory or authorized distributor.

Products must be installed and maintained in accordance with HOTSTART Inc. instructions. Users are responsible for the suitability of the products to their application. There is no warranty against damage resulting from corrosion, misapplication, improper specification or other operating conditions beyond our control. Claims against carriers for damage in transit must be filed by the buyer.

Absolutely no material can be returned to HOTSTART Inc. without prior factory authorization.

Upon factory authorization, return the defective part or product, freight prepaid, to: HOTSTART Inc., 5723 E. Alki, Spokane Valley, WA 99212. Telephone (509) 534-6171; FAX (509) 534-4216.

Defective items will be repaired or replaced, at our option, at no charge. Such repair or replacements is the exclusive right of HOTSTART Inc. HOTSTART Inc. is not liable for labor costs incurred in removal, reinstallation, or unauthorized repair of the product or for damage of any type whatsoever including incidental or consequential damage. Some states do not allow the exclusion or limitation of incidental or consequential damages, so the preceding limitation or exclusion may not apply to you.

HOTSTART Inc.



HOTSTART®

P.O. Box 11245
Spokane Valley, Washington U.S.A 99211-0245

Phone: (509) 534-6171

Fax: (509) 534-4216

Toll Free Fax: (800) 224-5550

www.hotstart.com

Distributor

12-09